



This 2006 Edition of the Commercial Property Owner's Guide to Earthquake Safety replaces the 1998 Edition on October 1, 2006.



## Publishing Information

---

*The Commercial Property Owner's Guide to Earthquake Safety* was developed and published by the California Seismic Safety Commission. It was distributed under the provisions of the Library Distribution Act and Government Code Section 11096.

Copyrighted 2006 by the California Seismic Safety Commission  
All rights reserved

### **Legislation**

This guide has been developed and adopted by the California Seismic Safety Commission as required by the Business and Professions Code Section 10147.

### **Ordering Information**

Copies of this booklet are available from the California Seismic Safety Commission, 1755 Creekside Oaks Drive, Suite 100, Sacramento, CA 95833. To order call (916) 263-5506 or download via our website at <http://www.seismic.ca.gov/sscpub.htm>

### ***On the Cover:***

**The roof of this department store was not well connected to its walls and partially collapsed in Yucca Valley during the 1992 Landers Earthquake.**

# CONTENTS

	<i>Page</i>		<i>Page</i>
<b>INTRODUCTION</b> .....	1	<b>OTHER EARTHQUAKE-RELATED</b>	
Your Commercial Property and the Law .....	2	<b>CONCERNS</b> .....	26
Recommendations .....	3	Unbraced Building Contents .....	26
Summary of Major California Laws .....	4	Unattached Equipment .....	28
Property Tax and Insurance .....	5	Unbraced Ceiling Systems .....	30
Examples of Damage to Commercial Property ....	6	Large Windows .....	31
		Ceiling-Mounted Items .....	32
<b>EARTHQUAKE MAPS OF CALIFORNIA</b> .....	7	Partitions .....	33
Damaging Earthquakes Map .....	7	Building Contents .....	34
Major Earthquake Fault Map .....	8	Checklist for Building Contents .....	35
Simplified Earthquake Shaking Map .....	9		
		<b>NATURAL GAS SAFETY</b> .....	36
<b>ADDITIONAL RESOURCES</b> .....	10		
		<b>GETTING THE WORK DONE</b> .....	38
<b>EARTHQUAKE WEAKNESSES</b> .....	11		
Unbraced Water Heaters .....	12	<b>GEOLOGIC HAZARDS</b> .....	40
Walls Poorly Anchored to Floors or Roofs .....	14		
Unreinforced Masonry Walls and Parapets .....	16	<b>WHAT TO DO</b>	
Poorly Reinforced Concrete Walls and Columns	18	<b>DURING</b> EARTHQUAKES OR TSUNAMIS	43
Steel Frame Buildings .....	20	<b>BEFORE</b> EARTHQUAKES.....	44
Soft Story Multi-Unit Residential Buildings .....	22	<b>AFTER</b> EARTHQUAKES.....	46
Other Unusual and Irregular Building Types .....	23		
Other Vulnerable Features .....	24	<b>RESOURCE ORGANIZATIONS</b> .....	48
Poorly Anchored Exterior Cladding .....	25		
		<b>COMMERCIAL PROPERTY EARTHQUAKE</b>	
		<b>DISCLOSURE REPORT</b> .....	51
		<b>SAMPLE TAX EXCLUSION FORM</b> .....	53

# ACKNOWLEDGMENTS

## Seismic Safety Commission

Lawrence T. Klein, Chair, *Utilities*  
Hon. Richard Alarcon, *State Senate*  
(Saeed Ali, Alternate)  
Hon. Carol Liu, *State Assembly*  
(Donald Manning, Alternate)  
Mark Church, *Local Government*  
Lucille M. Jones, Ph.D., *Seismology*  
Celestine Palmer, *Insurance*  
Gary McGavin, *Architecture and Planning*  
Daniel Shapiro, S.E., *Structural Engineering*  
Bruce R. Clark, Ph.D., *Geology*  
Keith Wheeler, *Emergency Services*  
Jeff Sedivec, *Fire Protection*  
Dennis Mileti, *Social Services*  
Arul Arulmoli, *Soils Engineering*  
James Wattenburger, *County Government*  
Andrew Adelman, *Cities/Building Official*  
Vacant, *City Government*  
Vacant, *Mechanical Engineering*

## Seismic Safety Commission Staff

Richard McCarthy, Executive Director  
Robert Anderson  
Sue Celli  
Karen Cogan  
Veronica Ramirez  
Henry Reyes  
Henry Sepulveda  
Fred Turner, Project Coordinator

## The Commission gratefully acknowledges the assistance of the following public and private entities for information, expertise and images:

Association of Bay Area Governments (ABAG)  
California Association of Realtors (CAR)  
California Building Officials (CALBO)  
California Council of the American Institute of Architects (CC-AIA)  
California Geological Survey (CGS)  
California Department of Insurance (CDI)  
California Department of Real Estate (CDRE)  
California Office of Emergency Services (OES)  
Collaborative for Disaster Mitigation (CDM)  
Committee on Earthquake Safety Issues for Gas Systems  
Earthquake Engineering Research Institute (EERI)  
Humboldt Earthquake Education Center  
National Geophysical Data Center (NGDC)  
Pacific Earthquake Engineering Research Center (PEER)  
Sempra Gas Company  
United States Geological Survey (USGS)

**Disclaimer:** The effects, descriptions, recommendations, and suggestions included in this document are intended to improve earthquake preparedness; however, they do not guarantee the safety of an individual or a structure. The Seismic Safety Commission takes responsibility for the inclusion of material in this document. The State of California, the Seismic Safety Commission, and all contributors to this document do not assume liability for any injury, death, property damage, loss of revenue, or any other effect of an earthquake.

# INTRODUCTION

**Earthquakes**, especially major ones, are dangerous, inevitable, and a fact of life in California. Sooner or later another “big one” will occur.

Earthquakes:

- Occur without warning
- Can be deadly and extremely destructive
- Can occur at any time

As a current or potential owner of a commercial property, you should be very concerned about the potential danger to not only yourselves and others, but also to your property, its contents and functions.

The major threats posed by earthquakes are bodily injuries and property damage, which can be considerable and even catastrophic.

Most of the property damage caused by earthquakes ends up being handled and paid for by building owners.

- Earthquakes have caused over \$58 billion (in 2000 dollars) in direct property losses in California since 1971.
- Large earthquakes in or near major urban centers in California will disrupt the local economy and can disrupt the economy of the entire State.

However, proper earthquake preparation of your building can:

- Save lives
- Reduce injuries
- Reduce property damage
- Avoid prolonged disruptions of functions

As a commercial property owner, you can **significantly reduce** damage to your building by fixing a number of known and common weaknesses.

**This Booklet** is designed to assist you in filling out the Commercial Property Earthquake Disclosure Report (See page 51) when you sell your property.

This booklet is also a good primer to begin strengthening your building against earthquake damage.

It describes:

- Common weaknesses that can result in your building being damaged by earthquakes, and
- Steps you can take to correct these weaknesses.

*There are no guarantees of safety during earthquakes, but properly constructed and strengthened commercial buildings are far less likely to collapse or be damaged during earthquakes. The California Seismic Safety Commission advises you to act on the suggestions outlined in this booklet to make you and your property safer.*

## Your Commercial Property and the Law

**California State Law requires sellers of commercial property built before 1975 that have precast (tiltup) concrete or reinforced masonry walls and wood-frame floors or roofs to:**

- Deliver to the buyer, “as soon as practicable before the transfer,” a copy of *The Commercial Property Owner’s Guide to Earthquake Safety*. (Government Code, Section 8893.2)

**California State Law does not require the seller to:**

- Hire someone to evaluate a commercial property.
- Disclose specific earthquake weaknesses of a commercial property.
- Strengthen a building before selling it.

***This Booklet:***

- Describes the most common weaknesses that can cause damage to commercial property in the event of an earthquake.
- Enables the seller to meet the State Law requiring this booklet be given to buyers of commercial property.
- Enables sellers to voluntarily disclose to buyers the typical earthquake weaknesses in commercial property.
- Provides owners with basic information about finding and fixing earthquake-related weaknesses.
- Provides general information about earthquake risks and directions for finding more information on earthquake safety.

## Recommendations...

### ***If You Are Selling***

*Before you sell your commercial property, the following steps are recommended:*

- If you list your property for sale through a real estate broker or agent, you are encouraged, but not required, to give the agent the completed disclosure report (See page 51) as soon as practical. Your agent can give the booklet and the form to the buyer for you.
- You are not required to hire someone to answer the questions on the disclosure form.
- You are not required to remove siding, drywall, plaster or other finishes to answer the questions.
- You are not required to fix the weaknesses before you sell your property.
- However, if you wish, you may get assistance from a licensed building contractor, architect, civil or structural engineer.
- Keep a copy of the form, signed by the buyer, as evidence that you have disclosed earthquake weaknesses.

You may find that you will get a better price for your property if you strengthen earthquake weaknesses before you sell.

### ***If You Are Buying***

*Before you agree to buy commercial property, consider the following recommendations:*

- Have a certified licensed building contractor, architect, civil or structural engineer inspect the property and give you an opinion regarding existing earthquake weaknesses and an estimate of costs to strengthen these weaknesses.
- Consider the location of the building: Is it in or near an Earthquake Fault Zone or in an area where it might be damaged by a landslide, liquefaction, or a tsunami? You may wish to hire a licensed geotechnical engineer and/or engineering geologist to check the stability of the land under the building.
- Negotiate with the seller the cost of strengthening, if any is needed. Local ordinances may require seismic retrofits if a change of occupancy classification or a major remodel is contemplated. In any case, if any weaknesses are not fixed, you may find that repair costs after a damaging earthquake can amount to more than your equity in the property. It is prudent to investigate these issues before you purchase your property.





# SUMMARY OF MAJOR CALIFORNIA LAWS RELATED TO SEISMIC SAFETY

Full wording of all California codes is available at: <http://www.leginfo.ca.gov>.

## Delivering this guide

Each seller of commercial property built before 1975 that has precast (tiltup) concrete or reinforced masonry walls and wood-frame floors or roofs must deliver to the buyer, "as soon as practicable before the transfer," a copy of *The Commercial Property Owner's Guide to Earthquake Safety* (this booklet) to inform the buyer of earthquake weaknesses that the property might have. (*Government Code*, Section 8893.2)

## Disclosing masonry weaknesses

Local governments in Seismic Zone 4, where a damaging earthquake is most likely to happen (see map, page 7), must inventory their unreinforced masonry buildings and establish a seismic risk reduction program for these buildings that includes the disclosure of the risk to the building owner (*Government Code*, Section 8875). Owners of buildings in Seismic Zone 4 who received notice that their buildings have load-bearing unreinforced masonry walls must post their buildings with signs warning that they may be unsafe in an earthquake (*Government Code*, Section 8875.8).

If the owner has not brought the building into compliance within three years, the owner shall not receive payment from any state assistance program for earthquake repairs resulting from damage during an earthquake until all other applicants have been paid. (*Government Code*, Sections 8893.1 to 8893.4)

## Earthquake fault rupture disclosure

The Alquist-Priolo Earthquake Fault Zoning Act prohibits building for human occupancy astride active faults. *Public Resources Code*, Section 2621 and following sections, requires sellers of commercial property to disclose to potential buyers if the property is located in a designated fault rupture zone.

## Landslides and liquefaction

The Seismic Hazards Mapping Act requires the state to prepare maps of the zones in California most susceptible to landslide and liquefaction hazards during earthquakes. *Public Resources Code* Section 2694 requires sellers of commercial property to disclose to buyers whether the property is in such a zone. This guide recommends voluntary disclosures of mapped landslide and liquefaction hazards during commercial real estate transactions.

## Publishing this guide

The Seismic Safety Commission is required to develop, adopt, update, and publish *The Commercial Property Owner's Guide to Earthquake Safety* containing information on geologic and seismic hazards, explanations of structural and nonstructural earthquake hazards, and recommendations for mitigating these hazards, as required by the *Business and Professions Code*, Section 10147.

# PROPERTY TAX AND INSURANCE

## Property Tax Reappraisal Exclusion

California law allows property owners to strengthen their buildings with approved seismic strengthening techniques without the improvement being included in reappraisals that usually raise the property value and the tax owed, according to the *Revenue and Tax Code*, Section 74.5.

If you make an addition, such as adding new rooms to your building, your property tax bill will increase. But a strengthening project to help your building resist earthquakes will not add to your property taxes.

To receive the exclusion you must file a claim form with your county assessor. The work must also be approved as appropriate seismic strengthening by your local building department.

A sample form from the County of Santa Clara is attached on page 53. This form may vary in each county.

## Earthquake Insurance

Earthquake insurance is typically not part of your property owner insurance policy.

The cost of any earthquake insurance policy is based on a number of factors, including your property's location, age, construction type, and value. One thing to consider is to compare your building's expected damage to the deductible and the insurance premiums that would apply to your building if it were insured. You may wish to consult a licensed civil or structural engineer for more specific information on your potential for damage.

Each property owner should consider his or her individual risk factors and then weigh the cost of earthquake insurance coverage against the benefits.

For more information, contact your insurance agent, who can also help you locate an earthquake insurer and estimate annual premiums and deductibles.

In 2005, only slightly more than 11 percent of all commercial property owners in California were insured for earthquakes and damage may fall below deductibles.

# EXAMPLES OF DAMAGE TO COMMERCIAL BUILDINGS



EERI

**Figure 1 - Partial Collapse of an Industrial Building.** Poor connections between the walls and the roof caused this collapse.



Los Angeles Times

**Figure 2 - Northridge Earthquake, Jan. 17, 1994.** Collapse of the lower, soft story of this apartment rendered it uninhabitable.



Frannie Edwards

**Figure 3 - File cabinet drawers can slide open and unbolted cabinets can topple during earthquakes.**



Nabih Youssef

**Figure 4 --Department Store Collapse in Northridge 1994.** Fortunately no lives were lost since the earthquake occurred before store hours.



EERI

**Figure 5 - Concrete Parking Structure Collapse.**



Josh Marrow

**Figure 6 - San Simeon Earthquake, Dec. 22, 2003.** The Acorn Clock Tower Building constructed of unreinforced masonry collapsed killing two people.

# EARTHQUAKE MAPS OF CALIFORNIA

## Damaging Earthquakes in California

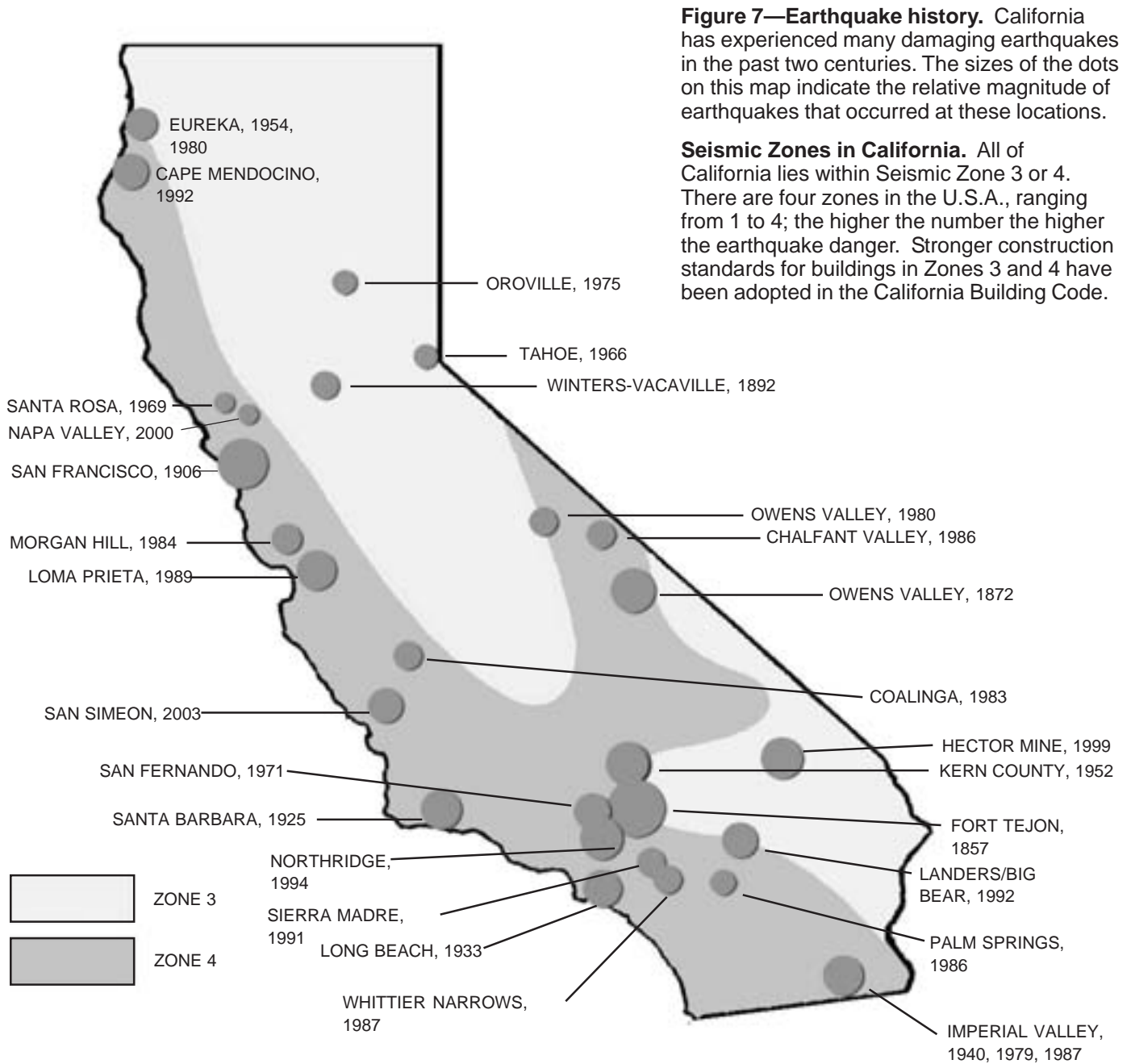

Source: California Geological Survey; Earthquake History of the U.S., U.S. Department of Commerce and Interior, 1982; Records of California Office of Emergency Services; compiled and revised by California Seismic Safety Commission, 2004; International Code Council, California Building Code 2001 Edition.

## Major Earthquake Faults in California

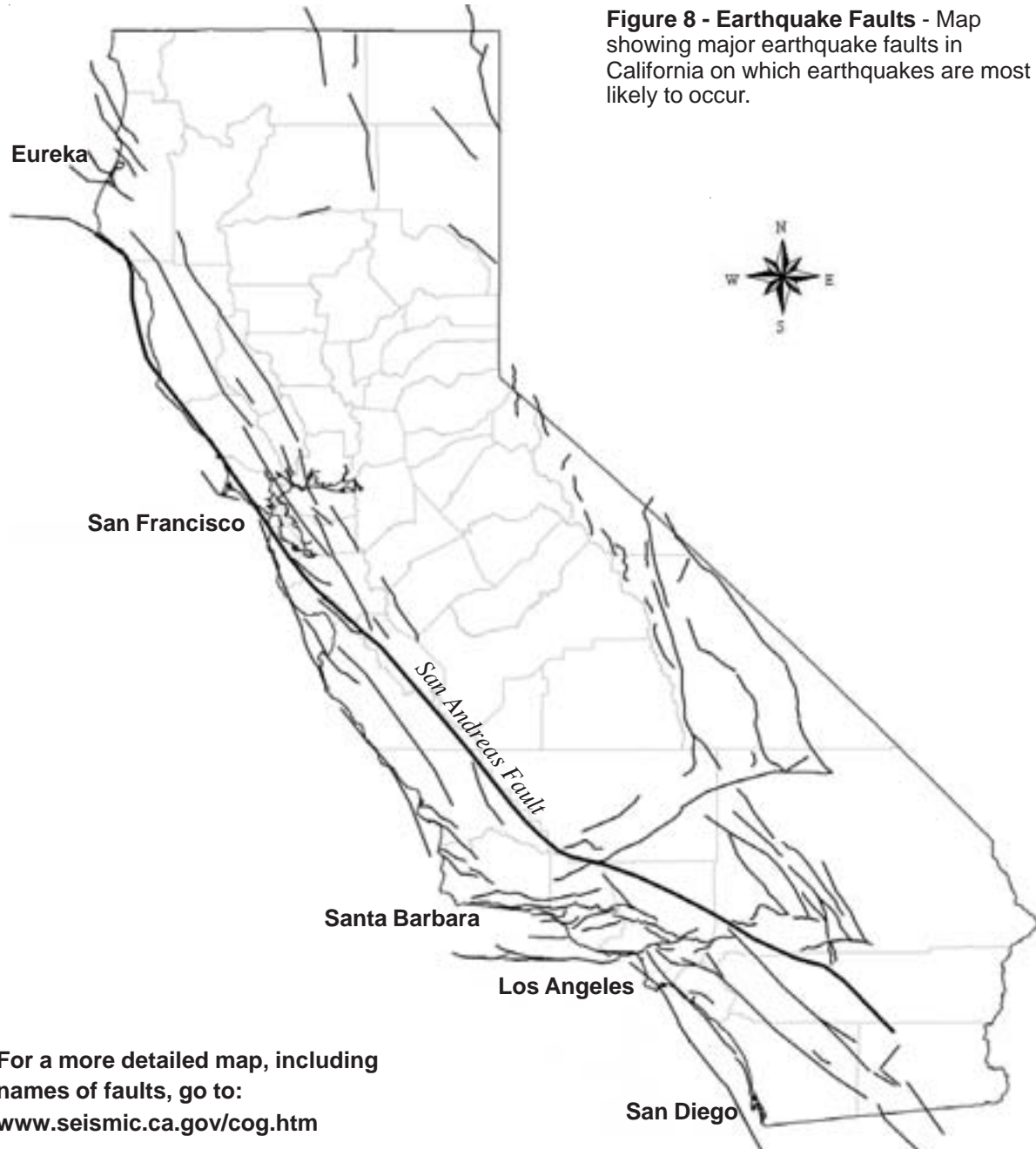

Map courtesy of California Geological Survey. Fault locations modified from seismic sources used in Revised 2002 California Probabilistic Seismic Hazard Maps.

## SIMPLIFIED Earthquake Shaking Potential Map for California

**Figure 9 - Earthquake Shaking Potential Map** - This map shows the relative intensity of ground shaking and damage in California from anticipated future earthquakes.

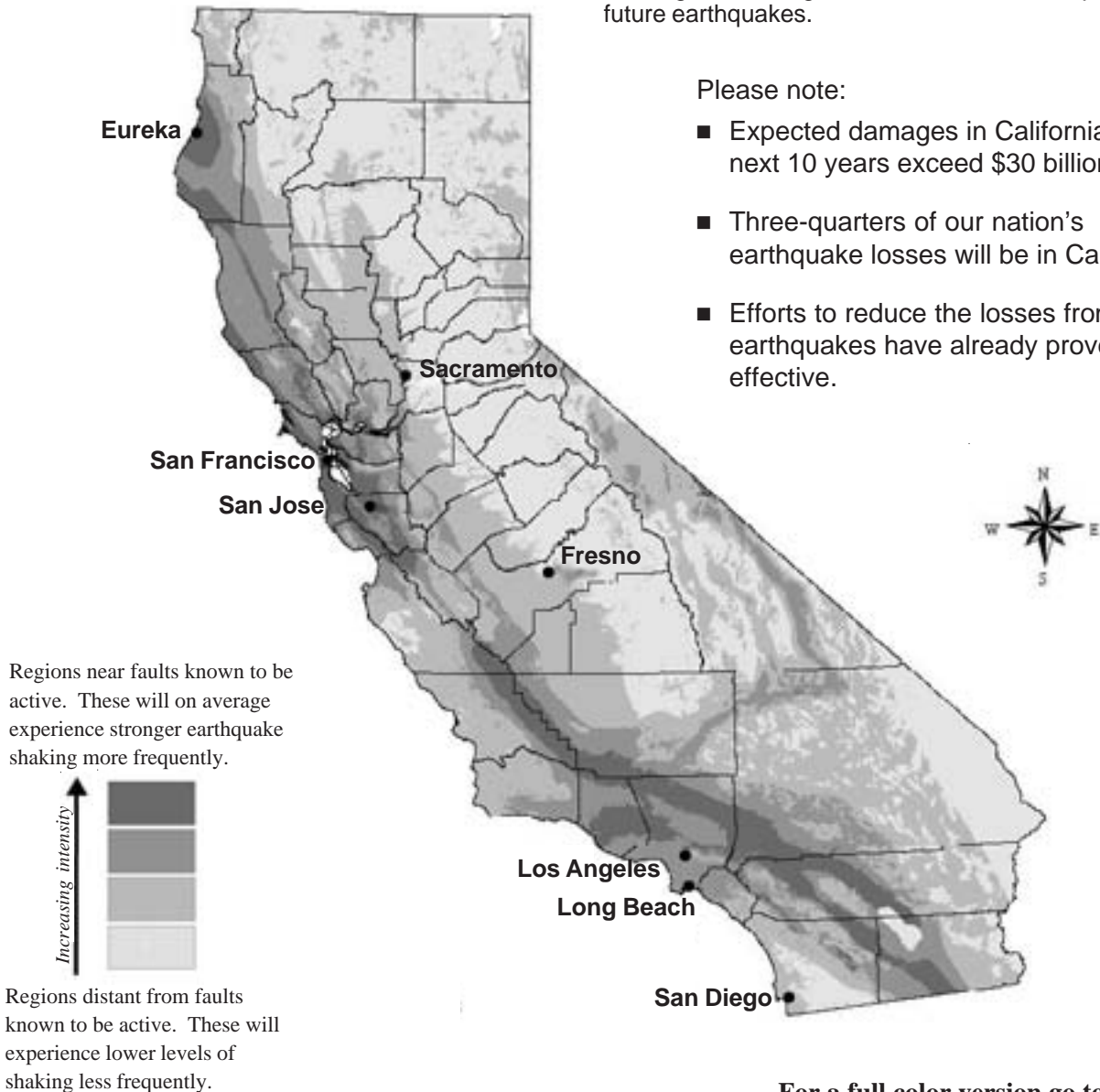

Data source: California Seismic Safety Commission, California Geological Survey, Governor's Office of Emergency Services, and United States Geological Survey, April, 2003, Earthquake Shaking Potential for California, California Seismic Safety Commission Publication No. 03-02.

# ADDITIONAL RESOURCES

There are many additional resources available. Some are web sites and some are books or pamphlets.

- The California Seismic Safety Commission has created a webpage that provides links to other sites that are appropriate for commercial property owners interested in improving the earthquake safety of their buildings.

Visit [www.seismic.ca.gov/cog.htm](http://www.seismic.ca.gov/cog.htm)

- FEMA also provides a wide variety of information suitable for the commercial property owner, including the availability of, and registration for, federal disaster aid programs after a damaging earthquake or other disasters.

Visit [www.fema.gov](http://www.fema.gov)

- The Governor's Office of Emergency Services also offers helpful emergency preparedness and mitigation advice for the public.

Visit [www.oes.ca.gov](http://www.oes.ca.gov)

# EARTHQUAKE WEAKNESSES

The earthquake weaknesses identified in this section, if not corrected, can result in one or more of the following:

- Injury to occupants and bystanders
- Severe damage to your building
- Broken gas and utility lines
- Fires from broken gas or electric lines
- Damage to floors, walls, and windows
- Damage to the contents in the building
- Damage to the foundations



## ***Remember that:***

- Retrofitting before an earthquake is relatively inexpensive.
- Doing major structural repairs to your building after an earthquake is very expensive.
- Sometimes the damage is extensive enough to require the entire building to be demolished.
- After an earthquake, there is usually a shortage of available licensed contractors and engineers in the impacted area, because of the sudden high demand for their services.
- An appropriate seismic retrofit will reduce future earthquake damage and save you money in the long run.
- Poor quality in building design and construction may also result in earthquake damage, so insist on high quality and strict compliance with building codes when buying, altering, and retrofitting.

*Consult your local Building Department and/or a licensed architect or civil/structural engineer for more detailed information.*

## The Problem

If water heaters are not properly braced, they can topple over during an earthquake causing:

- Broken gas lines and gas leaks
- Fires causing major damage to commercial properties
- Broken water lines and flooding

## How to Identify

- ✓ Is the water heater free-standing?
- ✓ Are there straps or other types of restraints securing the water heater?
- ✓ Are there straps or restraints bolted to the studs?
- ✓ Are there flexible pipes for water and gas connected to the water heater?

## Remember

- Replacing a water heater after an earthquake can cost more than \$500.
- Repairing fire damage and flooding damage can cost several thousand dollars, including the entire cost of your building!
- There are many different ways of strapping a water heater. One example is shown on the next page. (See page 13)
- Check with your local Building Department for details of local requirements.
- Know where your main water valve is so that you can shut it off if you have a water leak.
- Know where your main gas valve is so that you can shut it off if you hear or smell a gas leak. (See page 36)

Water heater



**Figure 10** - The unbraced water heater in this building fell during an earthquake; the resulting fire destroyed the building.

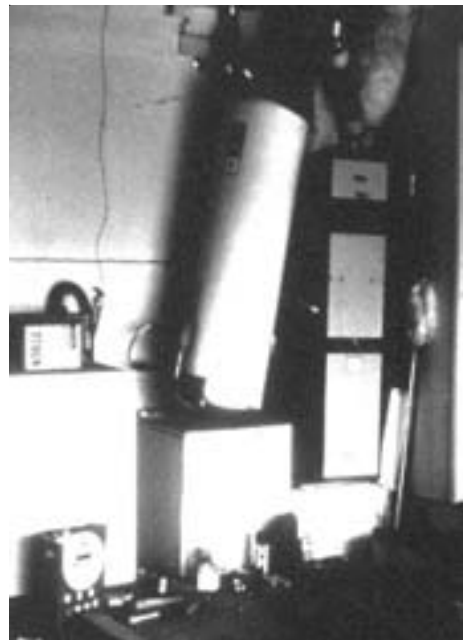

**Figure 11** - This unstrapped water heater tipped over during the 1984 Morgan Hill Earthquake. Fortunately gas and water lines were not ruptured.

Water heaters must be braced (securely attached) to the studs in a wall. California law requires water heaters to be braced at the time of sale, or when a new water heater is installed. (Health & Safety Code Section 19210 to 19217)

## The Solution

There are many solutions – all relatively inexpensive when water heaters are located near walls.

- Purchase and install a strap kit or bracing kit from your local hardware store. Be sure the kit is certified by the State Architect.

Other options include:

- Have a licensed plumber strap your water heater according to code.
- Use metal tubing or heavy metal strapping and lag screws and washers to secure the water heater to the wall studs.

The gas and water lines should also have flexible pipes. These are safer than rigid pipes during an earthquake.

Be sure to check the straps once a year. They may come loose due to vibrations, or other causes.

For water heaters not located near walls, consult a qualified engineer or architect.

## How-to Resources

- Your local hardware store
- [How to Brace Your Water Heater](#), City of Los Angeles, Department of Building & Safety, Information Bulletin #P/PC 2002-003, June 14, 1999.
- [How to Secure Your Water Heater](#), Governor's Office of Emergency Services, 2003.

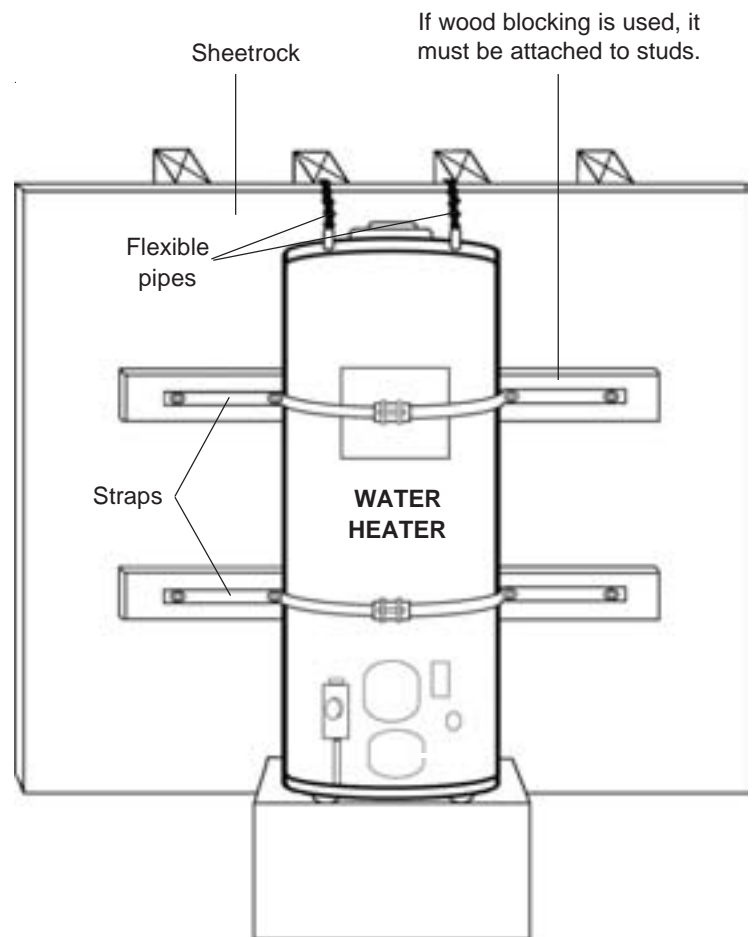

**Figure 12: One Method of Water Heater Bracing.** Straps and screws visible with water heater in a garage installation. You may need to add wood blocking.

**The Problem**

When earthquakes shake the ground, the various parts of buildings may move in different directions. If the connections (anchorage) between concrete or reinforced masonry walls, wood floors, and roof are weak, walls can pull away. (See figure 13a, b and c.) And the building, or a portion of it, may collapse. Until the mid-1970s, California building codes did not require new buildings to have wall anchorage that was adequate to prevent separation between the walls and the roof.

The Northridge earthquake showed that some types of wall anchorage installed even after 1975 were not adequate to support the walls.

Poor wall anchorage is also common in unreinforced masonry buildings. (See figure 13d.)

**How to Identify It**

Hire a qualified civil or structural engineer to:

- ✓ Check buildings with precast (tiltup) concrete or reinforced masonry walls that were built before 1975 for wall anchorage.
- ✓ It is also a good idea to check all anchorages built before 1995 to ensure they meet post-Northridge Earthquake standards.
- ✓ Check unreinforced masonry building wall anchorages.

**Remember**

- A good time to check and fix wall anchorage is when you replace or patch your roof.

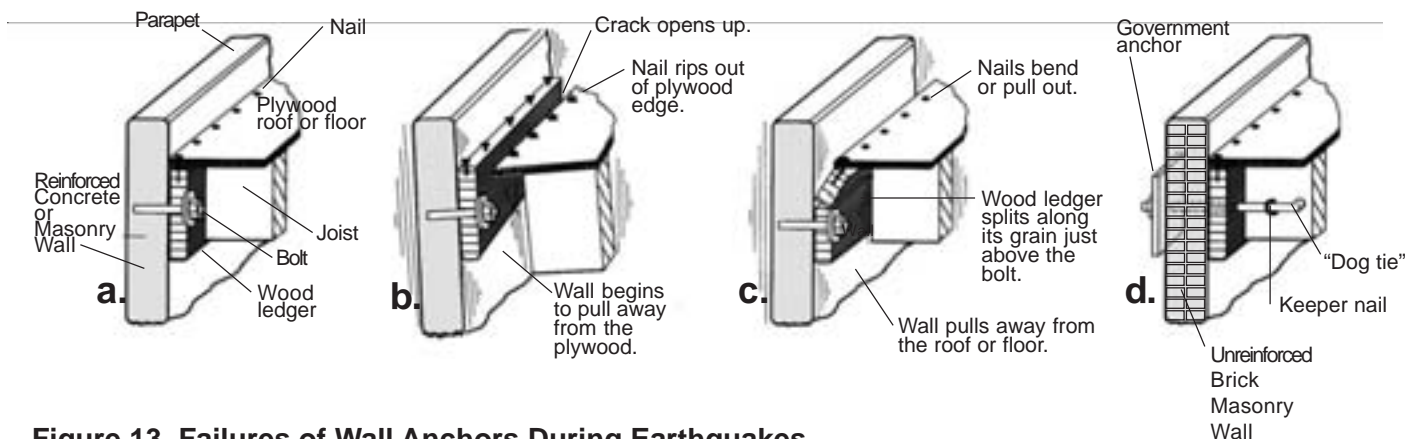
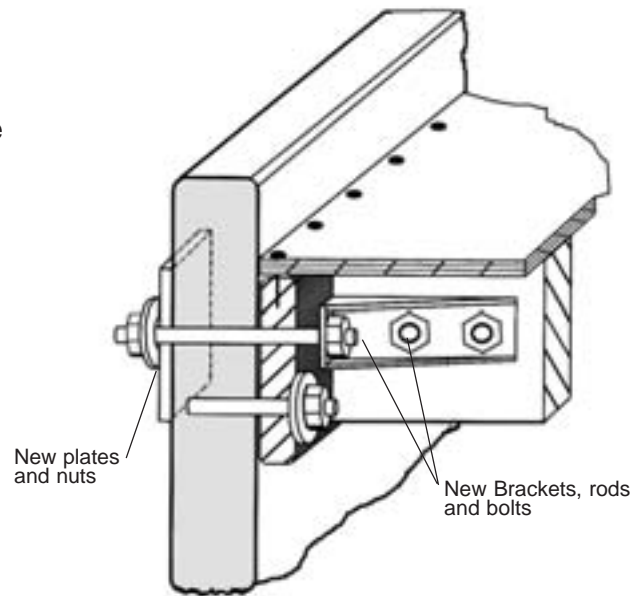

**Figure 13—Failures of Wall Anchors During Earthquakes.**

- a. The roofs and floors of many concrete tiltup and masonry buildings rest on ledgers bolted into the wall.
- b. When an earthquake occurs, the building’s movement may rip out the nails holding the roof in place,
- c. or split the ledger along the wood grain allowing the roof to collapse.
- d. “Dog ties,” also known as government anchors, will not always prevent unreinforced masonry walls from separating from floors or roofs

## The Solution

- If you suspect your building has poor wall anchorage, consider hiring a qualified engineer or architect to determine the most cost-effective way to strengthen it.
- Technical information for engineers to use when designing strengthened wall anchors can be found in Appendix Chapter A2 in the *International Existing Building Code*, published by the International Code Council.
- Contractors can add new anchorage and continuous ties across the roof. Work can be done inside above the ceiling (see figure 14) or on the roof, at relatively low cost.



**Figure 14 — Strengthening Wall Anchors.** One of several ways to strengthen the connections between the roof and floor joists and the walls is to install brackets and rods that go through the walls and attach to the joists.



CA Seismic Safety Commission

**Figure 15 — Wall Anchors Can Prevent Failures Like This.** Even newer buildings are not immune to earthquakes. This reinforced masonry strip mall was built in the 1980's but did not comply with the building code. The wall anchorage failed in the 1992 Landers Earthquake. Its front wall fell into the parking lot.

**The Problem**

Buildings built of unreinforced masonry (URM) — brick, hollow clay tiles, stone, concrete blocks, or adobe—are very likely to be damaged in earthquakes because the mortar holding the masonry together may not be strong enough to resist earthquake forces.

These buildings are usually brittle; they cannot flex and return to their original shapes as wood-frame buildings can. In addition to the danger of buildings’ collapsing during earthquakes, masonry can peel off the tops of walls, pull away from floors or roofs, and fall on people, neighboring buildings, or streets below.

Even if your building is safe, your neighbor’s unreinforced masonry building may damage your building, injure your employees or tenants, or disrupt commerce in your area.

**How to Identify Unreinforced Masonry**

If walls are made of brick or stone (which you can determine from the outside unless the walls are covered), check to see if they have “header courses” of bricks turned endwise every five or six rows (see figure 16) to hold unreinforced brick walls together. If the building was built before 1940, the walls are most likely unreinforced.

If walls are made of concrete block, it can be difficult to determine whether reinforcing steel was added during construction. The services of an experienced testing laboratory may be able to determine whether reinforcing steel is present. Otherwise, consulting the building’s plans, which may be on file with the building department, might be the only way to tell without damaging the wall.

**How to Identify Unbraced Parapets**

Parapets are tops of walls that extend up above roofs. Unbraced parapets have no visible steel members connecting the top or side of the parapet to the roof.



*J. Dewey, USGS, Courtesy of NGDC*

**Figure 16 -** The second-story wall of this unreinforced masonry building was not well-tied to the roof, and the building collapsed during the 1994 Northridge earthquake.

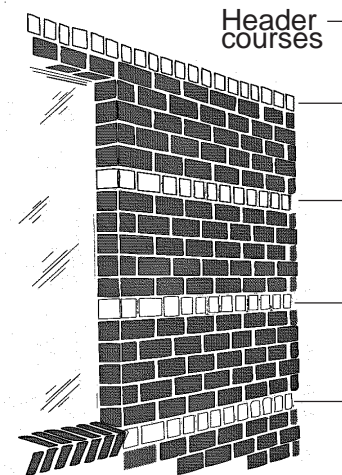

**Figure 17 – Header courses.** Header courses of bricks are usually placed endwise every six or so rows in unreinforced masonry walls to tie the outer layer of bricks to the layers inside the wall.



*Seismic Saerly Commission*

**Figure 18 - Parapets.** They are the tops of walls above the roof can fall off buildings like this one nearly did in Rio Dell during the 1992 Cape Mendocino Earthquake.

**The Solution**

Strengthening unreinforced masonry requires anchoring the walls to the floors and roof, adding interior partitions or walls, installing braces, or other measures. Strengthening will greatly reduce the hazards to life but may not guarantee that unreinforced masonry buildings will be repairable after an earthquake. Unreinforced masonry is a weakness that requires the services of a qualified and experienced engineer or architect to correct.

**Notify the Public with Warning Signs**

If your unreinforced masonry building is located in seismic zone 4 (see page 19) and you received notice from your local government that it contains unreinforced masonry bearing-wall construction, owners must post signs at entrances that say:

**This is an unreinforced masonry building.**

**Unreinforced masonry buildings may be unsafe in the event of a major earthquake.**

The sign must be in a conspicuous place at the entrance of the building, it must be at least 5 inches by 7 inches, and it must be lettered in bold type no smaller than 30 points in size. This posting requirement does not apply to unreinforced masonry buildings if the walls are non-load-bearing and have steel or concrete frames.

If this placard was not installed prior to January 1, 2005, owners are required to install the following 8 inch by 10 inch sign (*Government Code, Section 8875.8(a)*):

**Earthquake Warning.**

**This is an unreinforced masonry building.**

**You may not be safe inside or near unreinforced masonry buildings during an earthquake.**

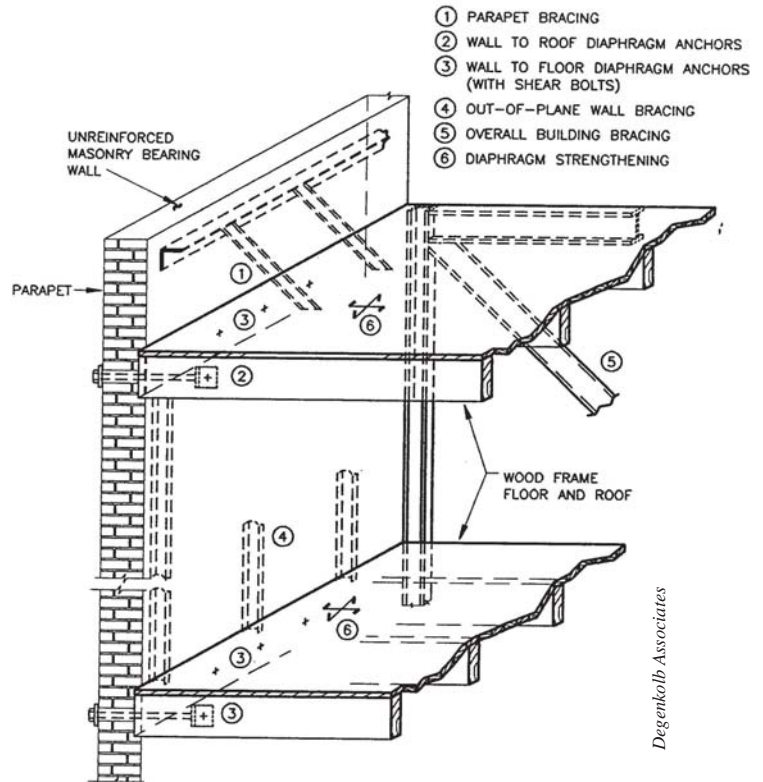

**Figure 19 - Ways to Retrofit URM buildings.**

Owners that retrofit their buildings can take down warning signs or replace them with the following:

**This building has been improved in accordance with the seismic safety standards of a local building ordinance that is applicable to unreinforced masonry.**



**Figure 20 - Unbraced Parapets can Injure and Kill - This parapet on the front of the building in Figure 18 fell on the sidewalk.**

**The Problem**

By itself, concrete is brittle and easily cracked during an earthquake. But with the addition of reinforcing steel, concrete buildings can be made strong enough to withstand earthquake forces.

However, the concrete walls or columns of structures erected before 1975 often lack enough reinforcing steel to keep them from collapsing or being damaged beyond repair.

These buildings can pose the greatest threat to life in major earthquakes because, though total collapse of these buildings is rare, just one collapse could cause hundreds of deaths. In 1971, three concrete hospital buildings in the San Fernando Valley collapsed, killing 52 people; 43 people were killed in the collapse of a concrete freeway viaduct during the Loma Prieta earthquake of 1989. These structures lacked sufficient steel to confine the concrete and allow it to bend but not fall apart (See figure 21).

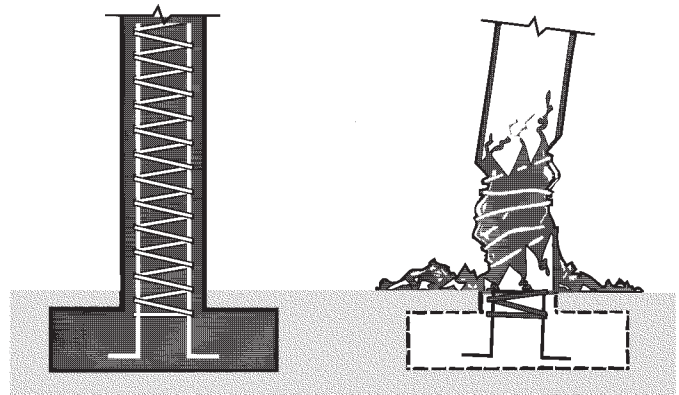

**Figure 21 –Lack of Reinforcing steel.** If the confining reinforcing steel in a column is too widely spaced (a), it will not be able to keep the vertical reinforcing bars and the concrete in place when it is shaken by an earthquake (b).

**How to Identify**

Hire an engineer or architect to help you review your building’s plans and determine whether it has this weakness, particularly if the building has many large windows, an irregular shape, or a tall, open first floor.



**Figure 22 -** Short columns in this parking structure failed in the 1994 Northridge earthquake. Modern building codes now require much more reinforcing steel for such short columns.



*A. Johnson*

**Figure 23 -** This medical office building’s exterior cladding affected the way its frame responded to shaking, and the columns failed during the 1994 Northridge earthquake. The building was demolished and all medical records inside were destroyed.

**The Solution**

New walls or bracing can be added, and columns can be wrapped with confining material, so that these buildings can survive ground shaking. A qualified engineer or architect can help you decide on the most cost-effective way to strengthen your building.

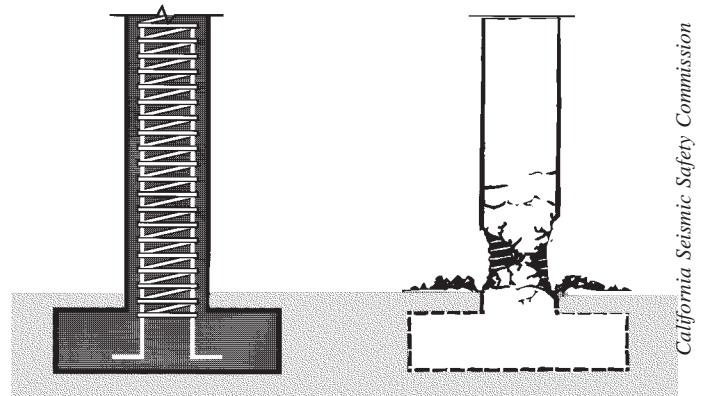

**Figure 24** - The addition of more confining steel (c) keeps the vertical reinforcing bars from buckling and the concrete from shifting so that the building continues to be fully supported (d) even if it is damaged in an earthquake.



**After the Earthquake**

**Figure 25** - The walls and columns holding up the Psychiatric Unit of the Olive View Hospital weren't adequately reinforced; they collapsed in the San Fernando Earthquake of 1971. It was a two-story building before the earthquake. Only because the earthquake occurred during an early hour of the morning, the building was fortunately not occupied and a large loss of life was avoided. This type of construction is common in older California commercial and institutional buildings.



**Before the Earthquake**

**The Problem**

In past earthquakes, fractures (cracks) occurred in steel frame buildings built before 1995 in two locations: (1) in welds and steel elements in or near steel beam-to-column connections (see figures 26 and 27); and (2) in column base plates (see figure 28).

Such fractures are often small and hard to detect because they may be covered by fireproofing, interior walls and ceilings, and exterior facades. Slender or thin-walled steel braces can buckle prematurely in buildings built before 1982. See figure 29).

The reasons for damage to steel members are not fully known but may include workmanship, design, welding procedures, and material characteristics.

Some buildings with subtle structural damage also will suffer movement-related damage such as cracked finishes around columns and beams, cracked or out-of-plumb partitions or door frames, damaged ceilings, and broken glass. In cases of extreme damage, partial collapse may be possible.

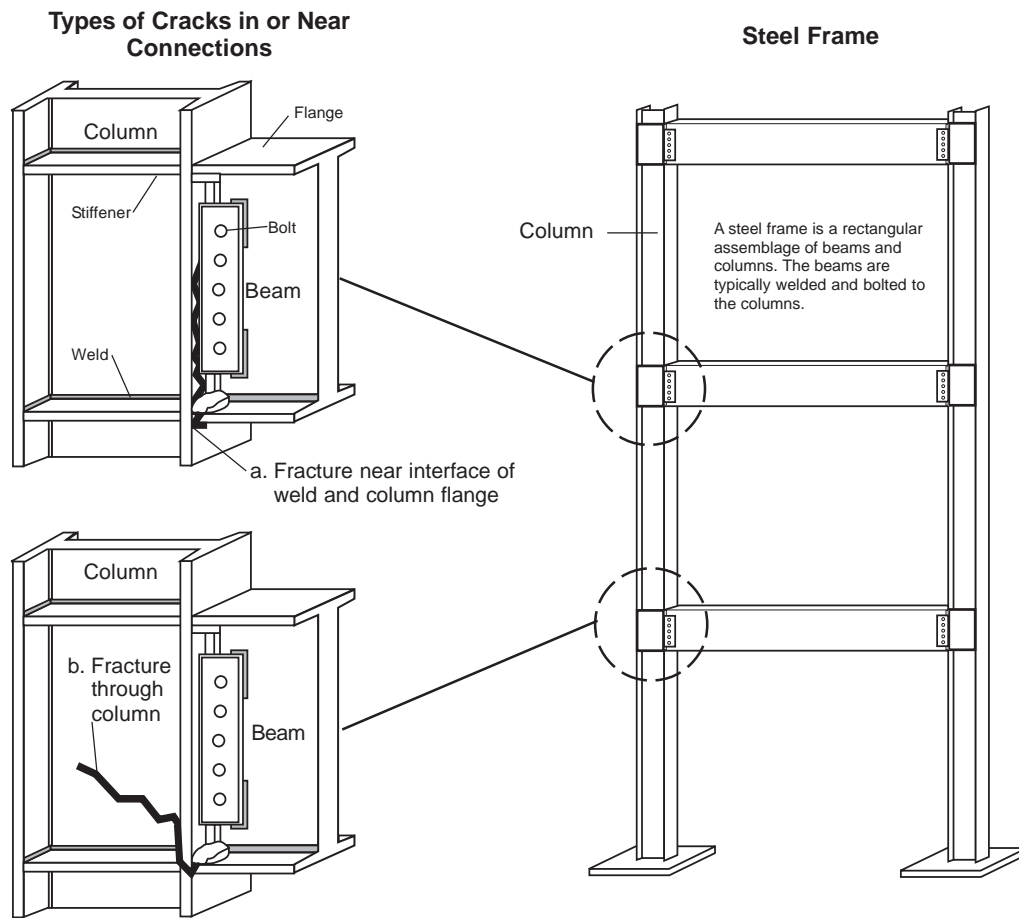

**Figure 26—Steel Frame. Two types of cracks found in steel frame buildings after earthquakes.**  
(Adapted from photo provided by Los Angeles Times.)

**How to Identify**

If your steel frame buildings have been exposed to strong ground shaking in the past and you have observed the damage described above, contact an appropriately experienced structural or civil engineer or architect to assess the need to investigate critical areas in the buildings. Owners of other steel buildings who are concerned about the potential for such damage are also encouraged to obtain qualified opinions.

Building investigations typically involve removing finishes and fireproofing at the beam column connections, visual observations, and testing, where appropriate. This work may disrupt occupants for a short time.

**The Solution**

Repair and retrofit techniques and recommended guidelines are currently available from the Federal Emergency Management Agency (FEMA 350 to 353), the American Institute of Steel Construction (AISC 2005 Seismic Provisions and AISC 358) and the International Code Council (ICC) (see “Resource Organizations” on page 48). Local government ordinances may also apply. Engineers should obtain and consider these latest guidelines, codes and standards when designing retrofits or repairs.



EERI

**Figure 27**—This steel frame connection unexpectedly cracked in the 1994 Northridge earthquake.



EERI

**Figure 29**—A six-story steel braced frame building was damaged after the 1995 Kobe Earthquake in Japan. 4,000 to 8,000 small commercial buildings and 1,000 to 2,000 large commercial buildings were destroyed or severely damaged in that event.



EERI

**Figure 28**—A 4-inch-thick steel plate supporting the base of a column at the Oviatt Library at CSU Northridge fractured in the 1994 earthquake.

**The Problem**

Apartments and condominiums with parking or commercial space on the first floor are prone to collapse if ground floor walls and columns are not strong enough to hold up the building during earthquakes.

**How to Identify**

Buildings with parking at the ground floor, or large amounts of windows and few solid walls can have earthquake weaknesses. Consult with a qualified engineer or architect to help you evaluate your building's condition.

**The Solution**

Soft, weak, or open front stories can be strengthened to prevent collapse. You should rely on the advice of a qualified engineer or architect.



*California Seismic Safety Commission*

**Figure 30**—Apartments with tuck-under parking like this can collapse. This building is leaning but did not collapse in the 1994 Northridge earthquake.



*J. Dewey, USGS*

**Figure 31**—A similar apartment building's soft story collapsed on cars during the same earthquake.



*EERI*

**Figure 32**—This modern wood-frame apartment building had a central driveway. It collapsed inward over unbraced entrances to crush first-story parking during the 1994 Northridge earthquake.

## The Problem

Buildings with irregular configurations, unusual designs, long spans, large assembly areas, or other unique features can be more vulnerable to earthquake damage than simple buildings. Numerous parking structures suffered partial collapse during the Northridge earthquake.

## How to Identify

Consult with a qualified engineer or architect to identify the hazards, if any, of unusual designs and features. A building that is anything other than a plain box with four walls, floors, and a roof needs careful engineering attention. Irregularities in the building's footprint can be earthquake weaknesses. Buildings with long spans over large assembly areas such as theaters, auditoriums, and churches should be carefully evaluated, since a collapse could be catastrophic.

## The Solution

The earthquake weaknesses of irregular or unusual building features can be reduced by strengthening or other means. You should rely on the advice of a qualified engineer or architect.



Karl Steinbrugge NISEE

**Figure 33** - This six story lift slab building collapsed in the 1964 Alaskan Earthquake.



Harold Engle NISEE

**Figure 34** - This unusual building with a tall story, long spans and large windows was severely damaged in the 1933 Long Beach Earthquake.

## The Problems

*Chimneys*—Unreinforced brick and stone chimneys often collapse in earthquakes. These chimneys should be braced or replaced to prevent injury or property damage.

*Signs, marquees, canopies*—These items should be braced so they do not pose a hazard to passersby. Check periodically to make sure their connections are not rusting away.

*Heavy roofs*—Buildings with heavy roofs (clay, tile, and slate, for example) shake more in an earthquake than buildings with lighter roofs. Such roofing materials may even fall off, injuring people and damaging objects below.

*Stairs, balconies, overhangs*—If these features aren't properly braced or attached to the building, they can collapse or prevent occupants from leaving the building after an earthquake.

*Dry rot, insect infestation, deterioration*—Dry rot, termites, boring beetles, or lack of maintenance can weaken a building and make it more prone to earthquake damage.

## The Solutions

If your property has one or more of the features described above, get an architect or engineer who is experienced in earthquake strengthening of existing buildings to give you a quick, preliminary evaluation.

Use such an evaluation to help you decide what to do to make sure your building and its occupants can survive a damaging earthquake.

Keep features such as children's play areas, outdoor restaurants, and storage areas out of the striking range of falling masonry, roof tiles, parapets, and overhangs.

Replace infested or deteriorated building material before you strengthen.



California Seismic Safety Commission

**Figure 35** - The chimney on this building fell on the stair-way in the 1992 Big Bear earthquake, cutting off a means of escape for persons on the second floor.



J. Dewey, USGS

**Figure 36** - Stairs to an apartment building collapsed during the 1994 Northridge earthquake.

**The Problem**

The cladding on the outside of some buildings can sustain damage and even fall off if it does not allow the building to flex when the ground shakes. Precast concrete cladding, with or without stone facing, is heavy. The steel connections holding it to the building must be strong enough to allow the building to move in an earthquake without failing. In addition, gaps or joints between cladding units must be large enough and in the right places to accommodate building movement.

**How to Identify**

Engage a qualified engineer or architect to help you evaluate the condition of cladding and its ability to allow for earthquake movement.

**The Solution**

Poor connections can be strengthened or replaced. You will need to hire a qualified engineer or architect.



**Figure 37** - Cladding on this store in Anchorage failed in the 1964 Alaska earthquake.



**Figure 38** - The sign on this commercial building fell in the 1979 Imperial Earthquake.

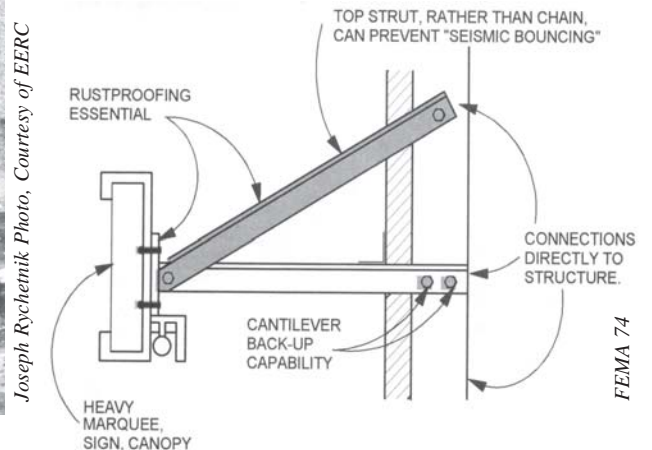

**Figure 39** - Simple retrofits can prevent signs from falling.

Joseph Rychemik Photo, Courtesy of EERC

Bob Reitherman/BSD, Inc. FEMA 74

FEMA 74

**The Problem**

The contents of your building can be damaged or can cause damage in earthquakes. They may injure your building occupants or block emergency exits; it can be expensive to repair and replace items that are broken. You should be concerned about contents, not only to protect your property but also to guard against deaths or injuries.

Earthquake shaking may cause light fixtures and bookshelves to fall, and other large items to topple or move across the floor (see figures 40 to 63). Equipment may be disabled or severely damaged. It may take considerable time and money to replace or repair computers, vital records, and specialized technical equipment. Heavy crates or boxes stacked high, such as those in warehouses or discount stores, can fall on tenants, employees, or customers.

**How to Identify**

Look around your building for items that could fall or move during earthquakes. Could your file cabinets fly open, allowing the contents to scatter on the floor? Could unanchored storage or display shelves topple or lose their contents?



*CA Seismic Safety Commission*

**Figure 41** - Pallets of canned goods stored in this building fell off the shelves during the 1989 Loma Prieta earthquake and pushed out the concrete wall of this Hollister warehouse.



*Degenkolb Associates*

**Figure 40** - Shelves like these can topple like dominos.



*Bill McKeivitt, EERI*

**Figure 42** - The storage rack collapsed in this warehouse-style retail store during the 1994 Northridge earthquake. Heavy items such as the sofa in the center of the photo crashed to the ground and could have injured employees and shoppers.

**The Solutions**

Door latches, braces, and fasteners to fix nonstructural hazards can be installed as part of your regular maintenance activities.

Fasten heavy equipment and furniture to the floor or to the studs in the walls.

Store heavy objects on low shelves or in areas that pose fewer hazards.

Make sure your employees or tenants secure items such as tall furniture or equipment when it is installed or moved.

See the Earthquake Checklist for Building Contents on page 35, Resource Organizations on page 48, and [www.seismic.ca.gov/cog.htm](http://www.seismic.ca.gov/cog.htm) for help in identifying and dealing with these hazards.



*Wiss, Janney, Elstner & Associates, Inc. FEMA 74*

**Figure 44—Toppled file cabinets.** In the 1994 Northridge Earthquake, businesses were disrupted.

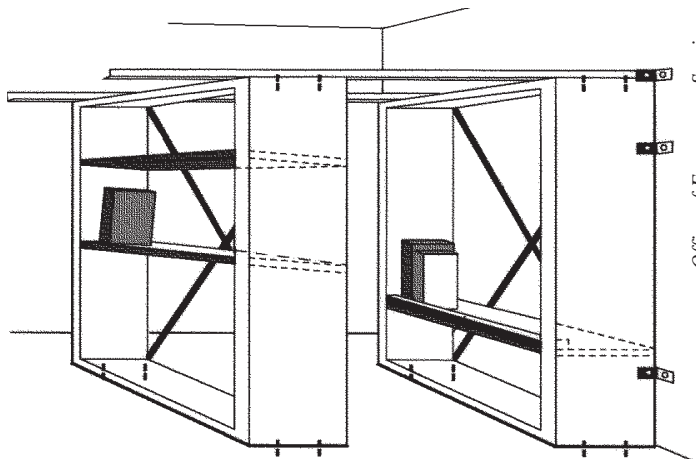

*Office of Emergency Services*

**Figure 43—Securing shelves and furniture.** Attach rows of shelving and other tall pieces of furniture to the wall and to each other for support; tilt the shelves or install shelf parapets or other restraints to keep objects from falling off shelves.

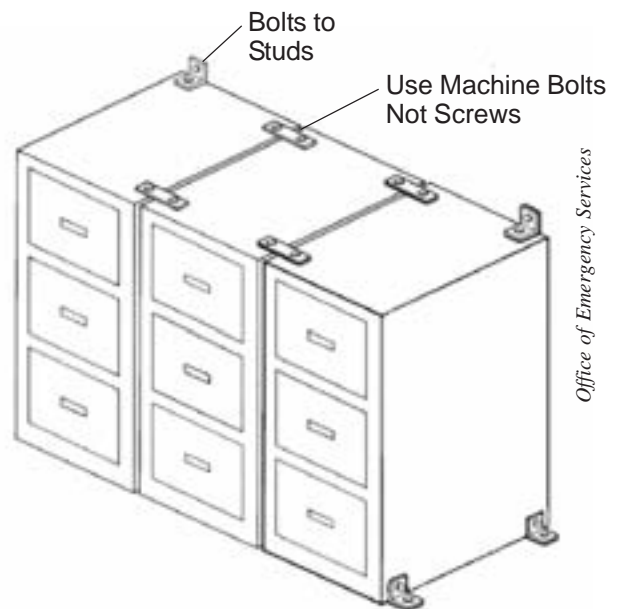

*Office of Emergency Services*

**Figure 45—Bolting file cabinets.** Bookcases and file cabinets should be bolted to the wall and to each other to keep them from falling. File drawers should have latches so they can't open in earthquakes.

## The Problem

If mechanical and electrical equipment such as air conditioners, water or propane tanks, boilers, and shop equipment are not securely attached to a wall, floor, or roof, it can topple or slide in earthquakes. If gas, electrical, water supply, or waste lines are broken when these items move, they may cause fire or flood damage.

## How to Identify

Examine mechanical or electrical equipment to see if there are anchors, metal straps, or braces around them that are bolted to the wall, floor, or roof. Make sure the bolts go into the wall studs or solid concrete, not just the drywall or plaster. Pull on the straps or braces to make sure they are secure and taut.



*Don Jephcott, EERI*

**Figure 46** - The support pedestal system of this oxygen tank at Olive View Medical Center was damaged after the 1994 Northridge earthquake, leaving the tank leaning. The tank is shown after it was removed to allow for installation of a replacement unit.

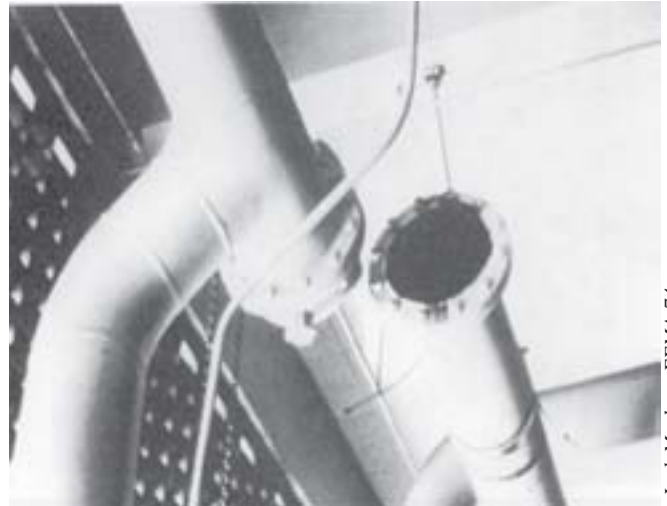

*Jack Meehan, FEMA 74*

**Figure 47** - This pipe joint separated during the 1971 San Fernando Earthquake.

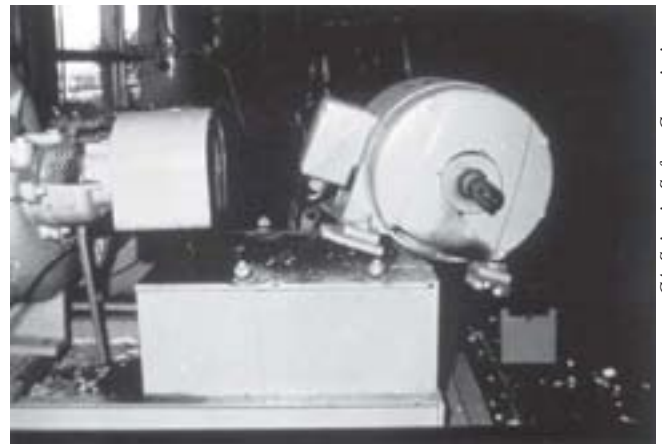

*CA Seismic Safety Commission*

**Figure 48** - This motor slid out from under the heads of the bolts holding it down. Tight bolts installed in holes—rather than slots—in its base would have held it in place.

**The Solutions**

The equipment can be secured to the structure by using bolts or braces (see figures 49 to 51).

Add flexible connections between the equipment and gas and water lines. Avoid rigid connectors to solid pipe, which may fail in earthquakes.

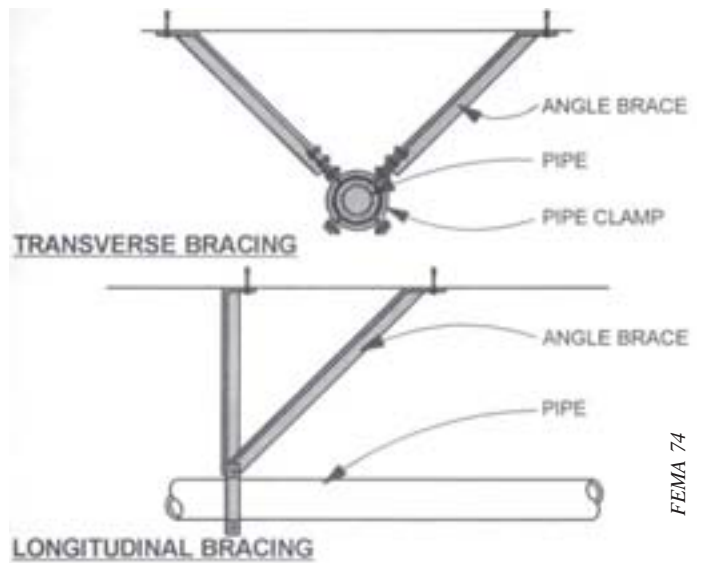

FEMA 74

**Figure 50—Bracing Pipes.** Adding diagonal braces to keep pipes from swaying can prevent damage and disruption.



**Figure 49—Bracing tanks.** Tank supports should be cross-braced as well as bolted to the floor.

Office of Emergency Services

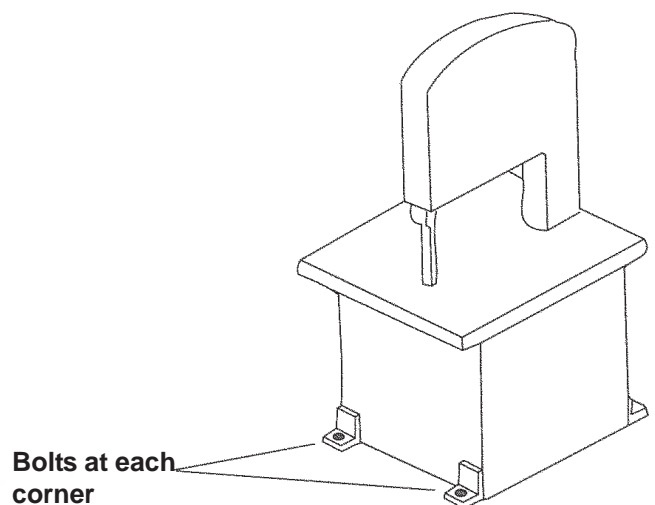

Office of Emergency Services

**Figure 51—Bolting equipment.** Light equipment can be bolted to a concrete floor with expansion bolts. For methods of securing heavier equipment, consult an engineer.

**The Problem**

Unbraced acoustic-tile ceiling systems can shake loose during earthquakes. Heavy light fixtures and duct vents are particularly hazardous to occupants if they are not properly connected to the roof or the floor above (see figures 52 to 54). Unbraced ceilings can hit fire sprinkler heads, which may release water and flood the building.

**How to Identify It**

Lift a ceiling tile and look up into the space above the ceiling. If the tiles seem loose in their frames, they may fall when the building begins to move. In rooms more than 12 feet wide, you should see diagonal wires and vertical pipe struts connecting the ceiling tiles' framework to the building's framing above, spaced every 12 feet.

Look for wide, secure supports for the ceiling framework around the room's edges.

Each light fixture and duct vent should be securely supported with at least two wires to the building framing above.

**What Can Be Done**

Wire hangers and braces can be added to ceiling systems, light fixtures, sprinklers, and vents. You can either make the additions yourself or hire a contractor.

Make sure there are gaps that will allow pipes to move where they pass through ceilings and partitions.



*Wiss, Janney, Elstner Associates FEMA 74*

**Figure 53** - This building sustained extensive interior nonstructural damage during the 1994 Northridge earthquake. Parts of the ceiling grid and tiles have fallen.

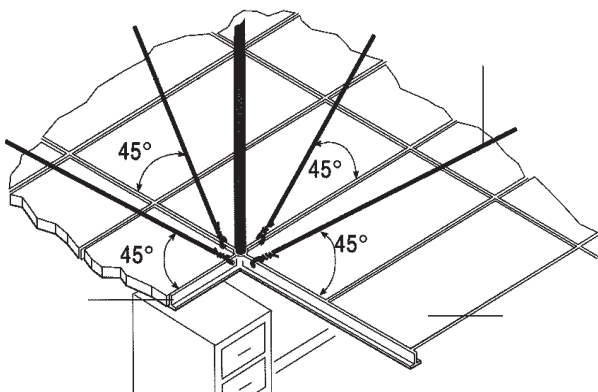

*Office of Emergency Services*

**Figure 52—Bracing ceilings.** This view from the top of the ceiling tiles shows diagonal bracing and struts to keep the tiles from falling in earthquakes.

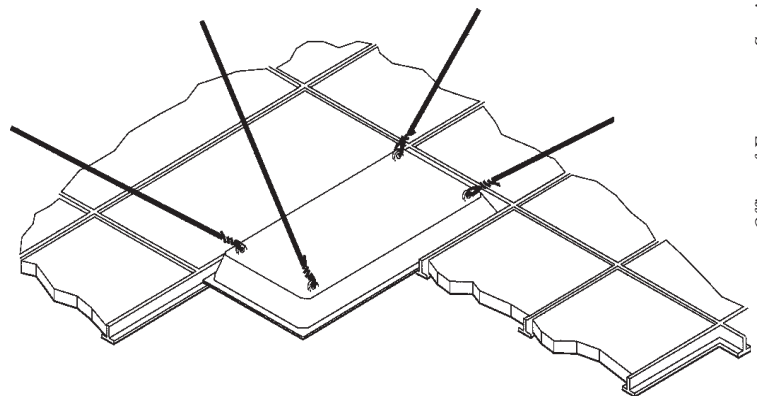

*Office of Emergency Services*

**Figure 54—Lighting fixtures.** Fluorescent lighting fixtures should be secured so they will not present hazards.

## The Problem

If a building has large windows, the glass may break when the ground shakes, especially if there are only narrow walls on each side of the windows. In a major earthquake, buildings with large storefront windows can lean over and even collapse if the front wall is inadequately braced. Buildings on crowded city blocks are especially prone to damage if the buildings are near enough to pound against each other during earthquakes.

## How to Identify It

Check to see if there are solid walls, diagonal braces, plywood panels, or heavy steel frames next to any large window. Such a window does not always indicate an earthquake weakness. There are no simple rules of thumb for determining whether or how much bracing is needed or where it should go.

You will need the help of an architect or engineer with experience in earthquake strengthening.

## What Can Be Done

New steel framing or plywood paneling can be installed around a storefront window. New window mullions can be added to replace a large piece of plate glass; this change will allow for more movement. Plastic film can be applied to the windows to keep the pieces from scattering if a window does break.

You should consult a qualified architect or engineer if you have large or numerous windows, especially on the ground floor of your building.



**Figure 55**—The front window of this Fortuna auto parts store broke in the 1992 Cape Mendocino earthquake.

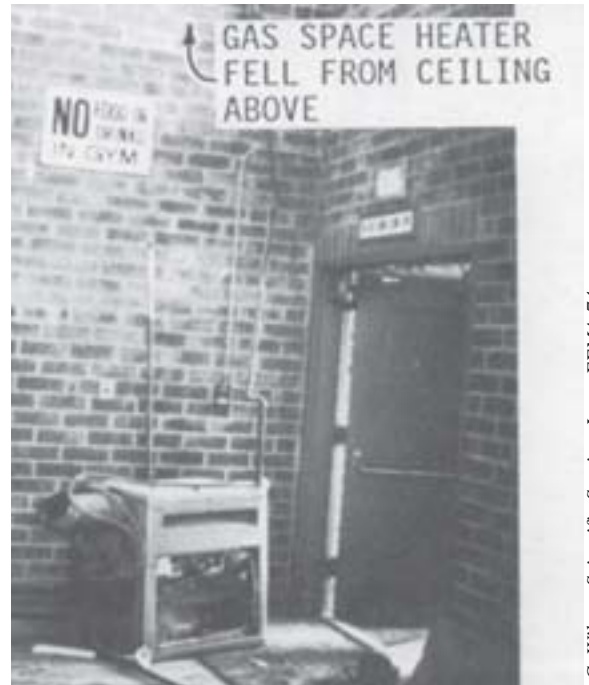

**Figure 56**—The windows in this San Francisco building probably broke because its frame flexed too much in the Loma Prieta earthquake of 1989.



Bob Reitherman

**Figure 57** - A broken sprinkler pipe caused extensive water damage after it was sheared off by ceiling movement in the 1994 Northridge Earthquake.



C. Wilton, Scientific Service, Inc. FEMA 74

**Figure 58** - Equipment that is not well connected to ceilings above can fall and cause serious injuries.

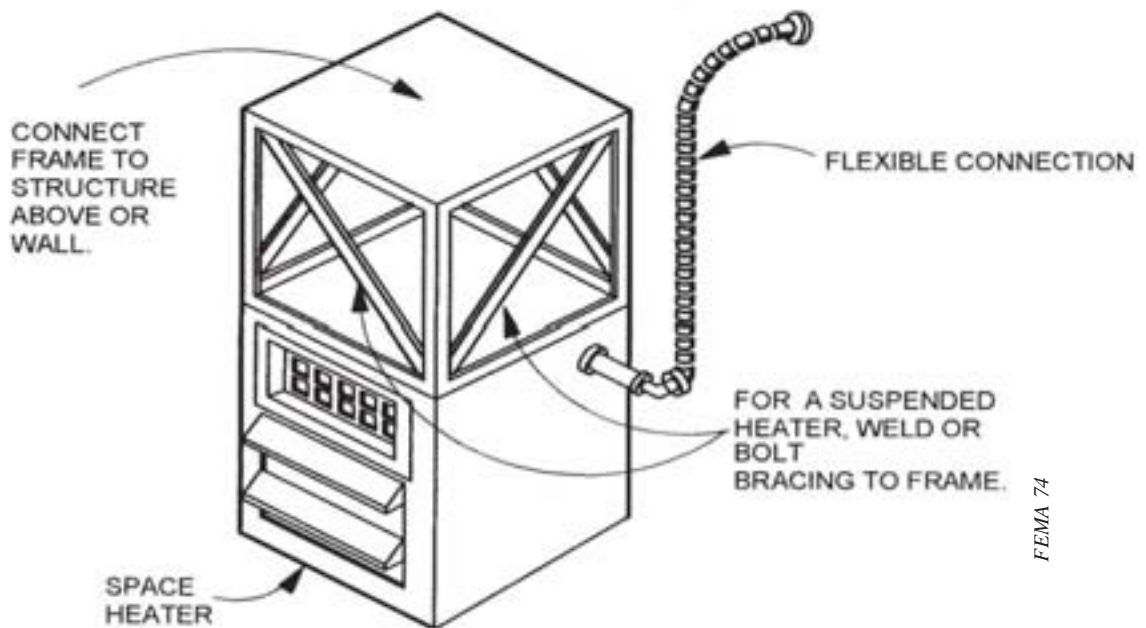

FEMA 74

**Figure 59** - Prevent suspended equipment from falling with proper connections and bracing.



**Figure 60** - Partitions and ceilings toppled onto office spaces during the 1994 Northridge Earthquake.

Wiss, Janney, Elstner Associates, Inc FEMA 74.

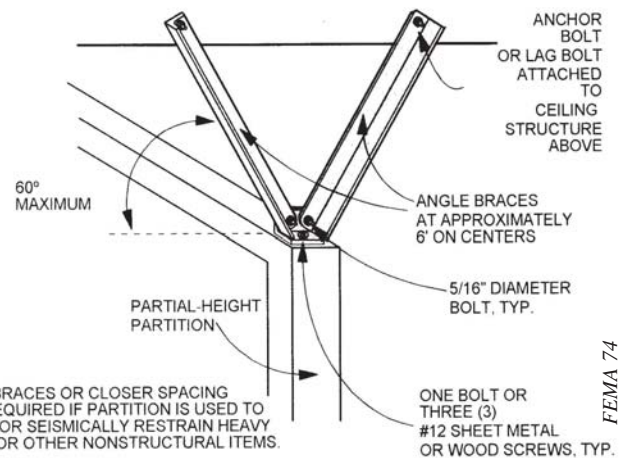

FEMA 74

**Figure 61** - Adding braces to the top of free-standing partitions can prevent them from toppling.

### Resources for How-to Attach & Brace Nonstructural Items:

- [Reducing the Risks of Nonstructural Earthquake Damage](#), FEMA 74.
- [International Building Code](#), 2006 Edition.
- [Minimum Design Loads for Buildings and Other Structures](#), ASCE 7-05, American Society of Civil Engineers.
- [Nonstructural Earthquake Hazards in California Schools](#), DSA, CSSC, OES, 2000.
- [Installing Seismic Restraints for Mechanical, Electrical, and Duct and Pipe](#), FEMA 412, 413, and 414, 2002, 2004.
- [Seismic Considerations for Steel Storage Racks](#), FEMA 450, 2005.

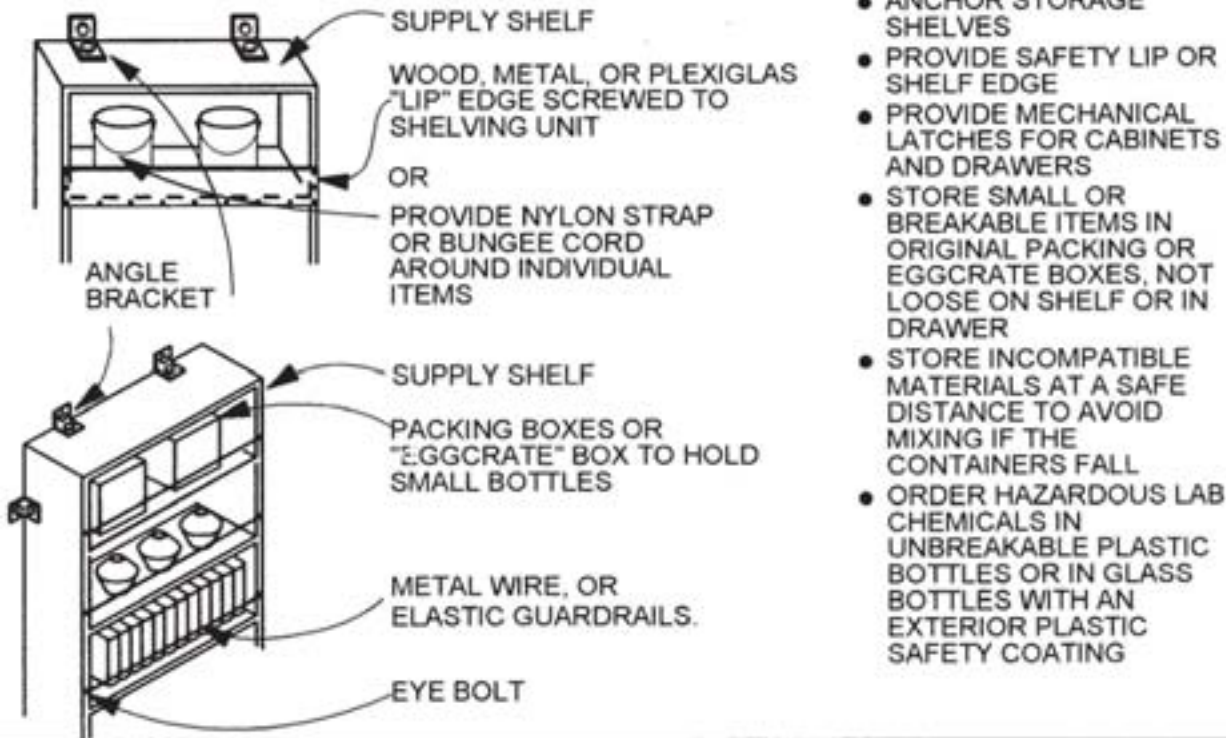

FEMA 74

**Figure 62** - Secure storage units from toppling by connecting them to walls. Keep contents from falling off shelves with lips or guardrails.

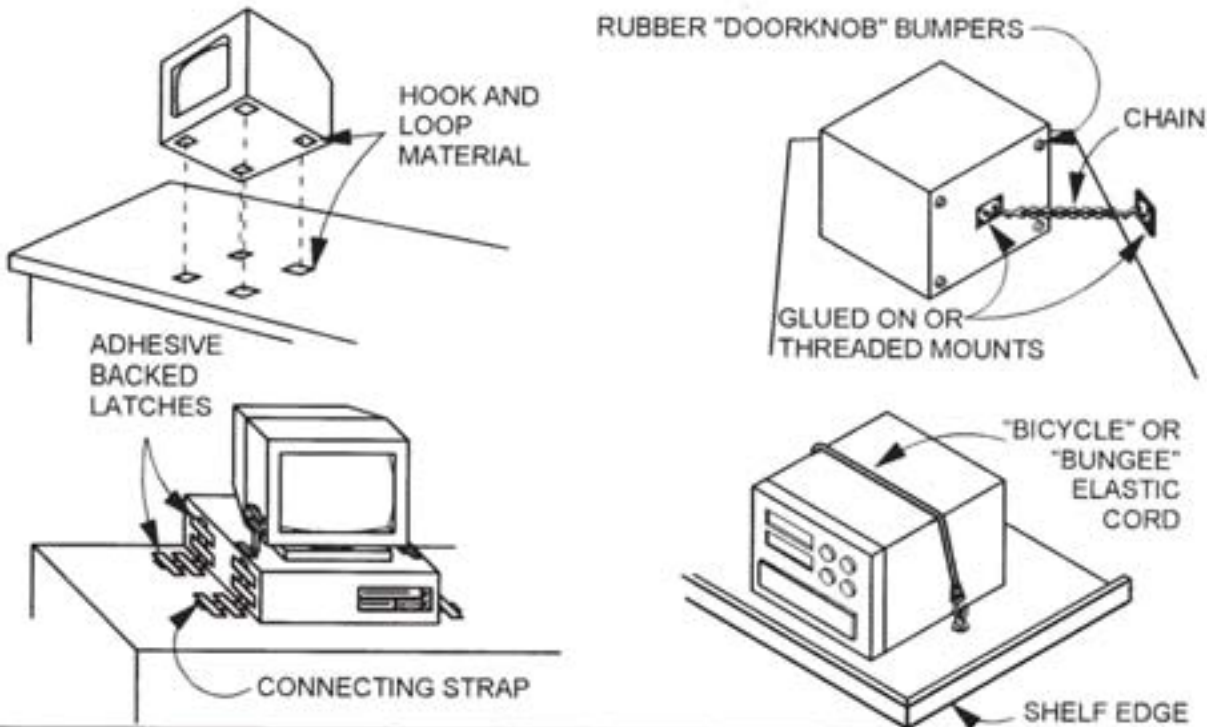

FEMA 74

**Figure 63** - Protect electronic equipment from falling off desks with straps or other mounting devices.

Every box you can check ahead of time is one less source of damage and expense after an earthquake. Review the “Earthquake Weaknesses” section of this booklet for additional weaknesses and concerns that you may need to fix.

- Desktop computer equipment is securely fastened down so it can't slide in an earthquake. (See Page 34)
- Data backup copies are kept off-site.
- Wall decorations, mirrors, hanging plants, fire extinguishers, and other heavy objects are attached with closed-eye hooks so they can't fall.
- Fragile objects (vases, display cases, and framed photographs, for example) are protected against tipping over or sliding off shelves.
- Tall filing and storage cabinets are attached to the wall or, if they are installed in rows, the rows are attached to each other so they cannot topple. (See Page 27)
- File cabinet drawers have latches so they cannot open during earthquake shaking, and heavy boxes or equipment stored on top of the files are secured so they cannot slide off.
- Office machines (computers, copiers, faxes, and printers, for example) and shop equipment are secured so they cannot slide or roll across the floor or fall off their stands. (See Page 34)
- Storage racks and shelves are braced and bolted to the floors and walls, and their contents are secured so they cannot slide off. (See Page 27)
- Compressed gas cylinders are fastened with a nylon strap, strong chains near the top and bottom, or a secure rack.
- Containers of laboratory chemicals or other hazardous materials are restrained so that they can't spill or slide off their shelves and break. (See Page 34)
- Movable partitions are securely braced, especially if they support bookshelves or contain breakable glass. (See Page 33)

# NATURAL GAS SAFETY

## The Problem

Natural gas piping and appliances can be damaged during earthquakes, causing gas leaks.

If ignited, this can result in fires which can burn part of, or, the entire building.

About one in four fires after an earthquake is related to natural gas leaks.

Gas leaks after an earthquake are more likely if:

- There are structural weaknesses
- Gas appliances are not anchored
- Flexible pipe connections are not used.

The primary concern is property loss from fire damage.

The potential for life loss is limited since most commercial properties have several safe exits.

## How to Identify

- ✓ Examine all natural gas appliances (water heaters, dryers, stoves, ovens, furnaces) to see if they are anchored to the floor or walls, and have flexible pipe connections.

## Plan Ahead

Locate your gas meter outside your building.

Identify the exact location of the shutoff valve and make sure that you have access to it.

Make sure you have a wrench that is readily available to turn off the gas when needed.

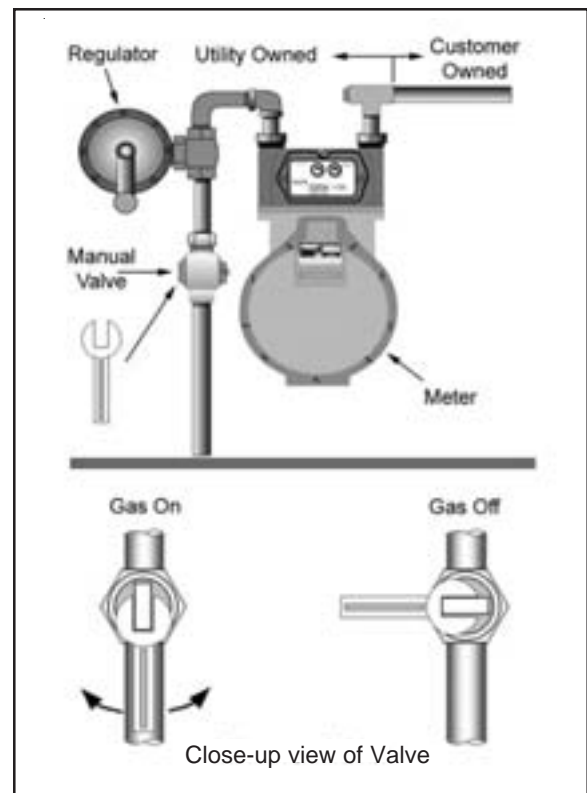

Figure 64—Manual Shutoff Valve Location

## Manual Gas Shutoff

- The most cost-effective way to manage the risk from natural gas is to know how and when to manually shut off the gas.
- Use the wrench to turn off the manual valve located at the gas meter (*See Figure 64, page 36*).
- Shut off your gas only if you:
  - Smell gas
  - Hear gas escaping
  - Suspect a broken gas pipe, appliance, vent, or flue.
- Manually shutting off gas to commercial and manufacturing buildings should be included in emergency response procedures for trained maintenance personnel.

## Remember

- Once the gas has been shutoff, service can be restored only by utility personnel or qualified plumbers.
- Restoration of gas service by qualified persons should include the inspection and repair of damaged systems.
- High demands for qualified personnel after an earthquake can lead to substantial delays in restoring natural gas service.

## Resources

- [Seismic Gas Shut-Off Valve Requirements in Los Angeles](#), City of Los Angeles, Department of Building & Safety, Information Bulletin #P/PC 2002-001, April 30, 2003.
- [Improving Natural Gas Safety in Earthquakes](#), California Seismic Safety Commission, Publication #CSSC-02-03, July 2002.
- [Gas Shutoff Valve Certification Program](#), Division of the State Architect.

## Automatic Gas Shutoff Options

There are a variety of automatic gas shut-off valves available. These cost more than manual shutoff valves and may provide additional safety but may also have some disadvantages including the potential for delays in service restoration and shutoffs when hazardous conditions may not exist.

The types of valves available include:

- Earthquake shake-actuated valves
- Excess flow valves
- Methane detectors
- Hybrid systems
- Others.

These can be installed on the “customer owned” side of the gas meter.

Consult your local Building Department because:

- Some installations will require building permits.
- Some local jurisdictions have adopted ordinances requiring automatic gas shutoff devices at the time of sale or during significant renovations.

# GETTING THE WORK DONE

## Plans, Permits, and Contractors

- Decide which strengthening project or projects you are going to do.
- Get the necessary building permits first.
  - Have a licensed architect and engineer draw up the necessary plans and specifications.
    - ✓ Interview two or three architects and engineers.
    - ✓ Ask for references or former clients.
    - ✓ Talk to references or former clients.
    - ✓ Compare experience, ideas, and fees.
  - Submit the plans for approval to your local building department.
  - Remember: the building codes are designed for your safety.

There are many publications that describe strengthening projects in detail.

Visit the California Seismic Safety Commission's website at [www.seismic.ca.gov](http://www.seismic.ca.gov), which provides many useful links.

- Get the documents that relate to your project and read them.
  - This will help you to better understand what the architect or engineer is doing, and also what the contractor is doing.
- The *International Existing Building Code* contains the best current guidelines. Ask your local Building Department how to comply with this Code.

- Select your licensed contractor.
  - First make sure the contractor is properly licensed.
  - Interview at least two or three contractors.
  - Ask your licensed architect or engineer for recommendations.
  - Ask for references or former clients.
  - Talk to references or former clients.
  - Compare experience, fees, and terms of contract.
  - Get at least three written bids for the construction work.
  - The lowest bid may not always be the best bid.
- Keep all plans, permits, and other records of your strengthening project.
  - Provide future buyers of your building with these.

If your building qualifies as "historical," you also may need to comply with the *California Historical Building Code*.

- Contact your local Building Department for further help with this.

## REMEMBER

Whether you do it yourself, or hire a contractor, **you need permits** from your local Building Department.

It costs far less to correct earthquake weaknesses before an earthquake than to repair the damage after an earthquake.

If your building is damaged in an earthquake, you will probably also have other costs such as lodging, medical, etc.

## DON'T HESITATE - MITIGATE!



## AFTER A DISASTER –

### ***Hire a Licensed Building Contractor!***

The contents of this section have been adapted from “After a Disaster, Don’t Get Scammed” by the Contractors State License Board.

#### ***After a Disaster...***

##### **DO NOT:**

- Rush into repairs, no matter how badly they are needed.
- Hire the first contractor who comes along.
- Accept verbal promises.

##### **DO:**

- Get proof that the person you are dealing with is a California licensed contractor appropriate for the work to be done.
- Get the contractor’s license number and verify that it is current and valid.
- Get a written contract that contains all the details of the job to be performed.
- Get at least three bids.
- Check references of other work the contractor has done, if possible, in your area.
- Develop a payment schedule with the contractor.
- Consider a completion bond on large projects.

*Contractors must be licensed for any job which costs \$500 or more, including materials and labor.*

#### ***Avoid Payment Pitfalls***

- By law, a down payment on a building improvement contract cannot exceed:
  - 10% of the contract price, or
  - \$1000whichever is less!
- Withhold at least 10% of the total contract price until the project is complete
- Do not make final payment until:
  - The building department has signed off on it,
  - You are satisfied with the job, and
  - Take a final walk-through to make sure work is complete and done correctly.

#### **Useful publications from the Contractor’s State License Board ([www.cslb.ca.gov](http://www.cslb.ca.gov)):**

- **What You Should Know Before You Hire a Contractor** - *Provides information about hiring and working with contractors.*
- **Building Improvement Contracts: Putting the Pieces Together** - *Provides answers about the legal requirements of contractors.*

# GEOLOGIC HAZARDS

Sellers of real estate in California are required to disclose to buyers certain information regarding natural hazards that can affect the property being sold. In addition to flood and fire hazard information, disclosure of seismic hazards is also required. Earthquakes are common in California because of the many earthquake faults located throughout the state.

This section:

- Describes briefly the basic geology-related hazards, and
- Introduces the government mapping programs that define which areas are susceptible to those hazards.

## **Ground Shaking:**

- Ground shaking causes 99% of the earthquake damage to California commercial properties.
- Areas near large active faults are more likely to be shaken severely than areas in the rest of the state.

## **Landslide:**

- Earthquakes can also trigger landslides.
- Earthquake shaking can cause the soil and rock to slide off a slope, ripping apart commercial properties on the slope and/or crushing commercial properties downhill (See *Figure 65*).

## **Fault Rupture:**

- An actual crack forms and the ground is offset along the two sides of a fault during an earthquake (See *Figure 66*).
- A building built over an active fault can be torn apart if the ground ruptures beneath it.
- If the building is built over a “creeping” fault – one that moves slowly with no earthquakes or a series of very small earthquakes – the damage may not be noticed for some time.



Patrica Grossi and Augustin Rodriguez, EERI

**Figure 65 - Landslide.** San Simeon Earthquake, December 22, 2003 Landslides on San Gregorio Road in Atascadero, California, only a short distance away from where the commercial properties with the most damage were located.



Robert A. Eplett, OES, CA

**Figure 66 - Fault Rupture.** Landers Earthquake of June 28, 1992, produced a surface rupture of over 50 miles along faults in the Mojave Desert.

### **Lateral Spreading:**

- Intense shaking during an earthquake can cause the soil to break into blocks which move apart from each other. This can cause damage to all ground surfaces including the foundation of a building (See Figure 67).

### **Liquefaction:**

- During earthquakes, loose, wet sandy soil can become almost like quicksand, and lose its ability to support structures. This can cause the foundation of a building to sink, break, or tilt (See Figure 68).

### **Tsunami:**

- A tsunami is a series of large sea waves caused by an underwater earthquake or landslide.
- Coastal areas are prone to tsunami damage.
- Tsunami waves can come from a great distance and can cause flooding and damage properties in low-lying areas along the shore.

### **Dam Failure:**

- Earthquake damage to a dam can cause sudden and devastating flooding of properties downstream.
- During the 1971 San Fernando Earthquake, the Lower San Fernando Dam above the San Fernando Valley was damaged. Had it failed, it would have flooded the properties below, causing many deaths and injuries. (See Figure 69). Risk of an aftershock forced residents and businesses in an 11-square mile area to evacuate for the next 3 days.
- California has some of the world's best standards for building and inspecting dams.

### **Recommendation:**

If you live in a low-lying coastal area or a dam inundation zone, become familiar with evacuation routes to higher ground and be prepared to evacuate such areas immediately after an earthquake.



NISEE Clearinghouse Project

**Figure 67 - Lateral Spreading.** Loma Prieta Earthquake, October 17, 1989. Lateral spreading damage levee road along the San Lorenzo River.



EERI

**Figure 68 - Liquefaction** caused differential settlement under this building and increased damage during the Loma Prieta Earthquake.



Robert A. Page, David M. Boore and Robert F. Yerkes, USGS

**Figure 69 - Lower San Fernando Dam** that was badly damaged by the 1971 San Fernando Earthquake.

# Earthquake Hazard Mapping

Enormous progress has been made in understanding how, why, and where earthquakes occur. This has led to the creation of maps that highlight areas having the highest likelihood of damaging earthquakes.

The following mapping programs have been developed to help Californians lead safer lives in earthquake country.

## ***National Seismic Zones***

The U.S. is divided into four major zones, each having a different likelihood of strong ground shaking. The earthquake hazard potential for the U.S., determined through a national program, has been generalized into four seismic zones, numbered Zone 1 through Zone 4. Zone 1 has the lowest earthquake danger and Zone 4 has the highest earthquake danger. **Most of the densely populated parts of California are in Zone 4.** (See Figure 7, page 7)

The National Seismic Zone map is published by the International Code Council (ICC) in the California Building Code.

## ***Earthquake Fault Zone Maps***

These maps are also known as the *Alquist-Priolo Earthquake Fault Zone Maps*, named after the California legislators who initiated the legislation that mandated these maps. The maps show regulatory zones around active earthquake faults prone to surface ruptures. The zone is about one quarter mile wide with the fault at the center of it.

## ***Seismic Hazard Zone Maps***

These maps show areas where landslides and liquefaction are most likely to occur during earthquakes.

## ***Tsunami Inundation and Evacuation Route Maps***

Maps for the Pacific Coast show areas where low-lying regions are exposed to tsunami inundation. These maps are in various stages of preparation and availability. Generally if your property is less than 35 feet above a shoreline, it may be vulnerable to tsunami inundation.

## ***Dam Inundation Maps***

These maps show the areas below major dams that may be flooded in the event of their failure.

## ***How are these Maps Used?***

The zones defined by the maps are at greatest potential risk when a major earthquake occurs. This is particularly the case when the earthquake occurs during or shortly after a heavy rainfall, which increases the likelihood of liquefaction and landslides.

California law requires that the information from the Earthquake Fault Zone and Seismic Hazard Zone maps be incorporated into local general plans, and any land-use planning or permitting ordinances. Cities and counties must establish regulations governing development within these zones.

Special geotechnical studies are required before buildings can be built in Earthquake Fault Zones or Seismic Hazard Zones.

Your local building or planning department can show you the National Seismic Zone Map as well as the other maps if they are available for your community. These maps, if they are available, may also be accessed at [www.seismic.ca.gov/cog.htm](http://www.seismic.ca.gov/cog.htm)

***The Seller of real estate within a hazard zone must disclose that the property lies within such a zone at the time of sale.***

# WHAT TO DO *DURING* AN EARTHQUAKE

**DROP!**



**COVER!**



**HOLD ON!**



1. IF YOU ARE **INDOORS**—STAY THERE! “**DROP, COVER AND HOLD ON.**” Get under a sturdy desk or table and hang on to it, or move into a hallway or get against an inside wall. Stay clear of windows, fireplaces, and heavy furniture or appliances. Get out of the kitchen, which is a dangerous place in earthquakes since it’s full of things that can fall on you. Don’t run downstairs or rush outside while the building is shaking or while there is danger of falling and hurting yourself or being hit by falling glass or debris.
2. IF YOU ARE **OUTSIDE**—**GET INTO THE OPEN**, away from buildings, power lines, chimneys, and anything else that might fall on you.
3. IF YOU ARE **DRIVING**—**STOP**, but carefully. Move your car as far out of traffic as possible. Do not stop on or under a bridge or overpass or under trees, light posts, power lines, or signs. Stay inside your car until the shaking stops. When you resume driving, watch for breaks in the pavement, fallen rocks, and bumps in the road.
4. IF YOU ARE ON OR NEAR A **STEEP HILLSIDE**—**WATCH OUT FOR LANDSLIDES**, falling rock, trees, and other debris that could be loosened by earthquakes.

## If You Feel a Strong Earthquake or Receive a Tsunami Warning When You are on the Coast

1. **DROP, COVER AND HOLD ON.** Watch for falling objects until the shaking is over.
2. **MOVE TO HIGHER GROUND** or inland away from the coast immediately. A tsunami may be coming. Go on foot if possible. The first waves may reach the coast within minutes after the ground shaking stops. The first wave is almost never the largest. Later waves may be spaced tens of minutes apart and can continue arriving for many hours.
3. **THERE MAY BE NO TIME FOR AUTHORITIES TO ISSUE A WARNING.** If you do not hear an evacuation announcement but notice a sudden drop or rise in water level or hear a loud noise coming from the water, nature may be warning you of impending danger.
4. **STAY AWAY FROM THE COAST.** Do not return to the shore after the first wave. Waves may continue to arrive for hours.
5. **LISTEN TO A RADIO FOR AN “ALL CLEAR”** before returning to the shore.

# WHAT TO DO *BEFORE* AN EARTHQUAKE

*The information contained in this section does not represent weaknesses in the earthquake resistance of commercial properties. It is valuable information to keep in mind to reduce risks to yourself, your building's occupants, and your building. These lists are only highlights of the actions you should take.*

---

## Gather Emergency Supplies

### ***Be sure you have these basic supplies on hand:***

- Fire extinguisher
- Adequate supplies of medications that you or your building's occupants are taking
- Crescent and pipe wrenches to turn off gas and water supplies
- First-aid kit and handbook
- Flashlights with extra bulbs and fresh batteries
- Portable battery-powered radio or television and extra fresh batteries
- Water for each building occupant for at least three days (allow at least one gallon per person per day) and purification tablets or chlorine bleach to purify drinking water from other sources
- Canned and packaged foods, enough for three days, and at least an additional four-day supply readily accessible for use if you are confined to your building. Don't forget a mechanical can opener.
- Camp stove or barbecue to cook on outdoors (store fuel out of the reach of children)
- Waterproof, heavy-duty plastic bags for waste disposal
- Copies of personal identification, such as driver's licenses, passports, and work identification badges, and copies of medical prescriptions and credit cards
- An extra set of car keys and building keys
- Matches in waterproof container
- Map of the area marked with places you could go and their telephone numbers
- Cash, account numbers, critical business records, copies of deeds, insurance policies, and a list of your financial institutions
- Special items, such as denture needs, contact lenses and supplies, extra eyeglasses, and hearing aid batteries
- Items for seniors, disabled persons, or anyone with serious allergies

---

## Plan Ahead



1. Create a building disaster plan; practice and maintain the plan.
2. Make and complete a checklist.
3. Plan escape routes from your building..
4. Conduct fire and emergency evacuation drills at least twice a year and include your pets in your evacuation and sheltering drills.
5. Test your smoke alarms once a month and replace batteries at least once a year in battery-powered smoke alarms (on daylight savings time days or on birthdays) .
6. Make sure each occupant of your building knows what to do no matter where they are when earthquakes occur.
  - Establish two meeting places where you can all reunite afterward: one right outside your commercial property, in case of a sudden emergency, and one outside your neighborhood in case you cannot return to your building or are asked to leave the area.
  - Find out about the earthquake plan developed by your children's school or day care.
  - Remember that since transportation may be disrupted, you may have to stay at your workplace for a day or two following a major earthquake. Keep some emergency supplies—food, liquids, and comfortable shoes, for example—at work.
  - Pick two out-of-town contacts:
    - A friend or relative who will be your **primary** contact,
    - A friend or relative who will be your **alternative** contact.
7. Know where your gas, electric, and water main shutoffs are and how to turn them off if there is a leak or electrical short; if in doubt, ask your utility companies. Make sure that all the adult building occupants can shut off the utilities.
8. Locate your nearest fire and police stations and emergency medical facility. Remember that telephones may not work after an earthquake. If you can, use your land line rather than your cell phone to call 911, but only if you need emergency help.
9. Talk to your neighbors—how could they help you, or you help them, after an earthquake?
10. Take a Red Cross first aid and cardiopulmonary resuscitation (CPR) training course.
11. If your commercial property is located near a steep hillside, in an area near the shore of a body of water or below a dam, check with your local building or planning department to see if you are in a landslide, tsunami or dam inundation zone. Plan for how, when, and where your building's occupants should evacuate.
12. Create a Financial Disaster Recovery Kit: Gather copies of your essential financial documents, backup critical computer files regularly, and store them in a fire-proof deposit box or safe.

# WHAT TO DO *AFTER* AN EARTHQUAKE

*Wear sturdy shoes to avoid injury from broken glass and debris.  
Expect aftershocks.*

---

## Check for Injuries

1. If a person is bleeding, put direct pressure on the wound. Use clean gauze or cloth, if available.
2. If a person is not breathing, administer rescue breathing. The front pages of many telephone books contain instructions on how to do it along with detailed instructions on other first-aid measures.
3. Do not attempt to move seriously injured persons unless they are in immediate danger of further injury.
4. Cover injured persons with blankets to keep them warm.
5. Seek medical help for serious injuries.

## Check for Hazards

1. *Fire or fire hazards.* Put out fires in your building or neighborhood immediately. Call for help, but don't wait for the fire department.
2. *Gas leaks.* Shut off the main gas valve only if you suspect a leak because of broken pipes or the odor of natural gas. Don't turn it back on yourself—wait for the gas company to check for leaks.
3. *Damaged electrical wiring.* Shut off power at the control box if there is any damage to your building wiring.
4. *Downed or damaged utility lines.* Do not touch downed power lines or any objects in contact with them.
5. *Spills.* Clean up any spilled medicines, drugs, or other potentially harmful materials such as bleach, lye, and gasoline or other hazardous materials.
6. *Downed or damaged chimneys.* Approach chimneys with caution. They may be weakened and could topple during aftershocks. Don't use a fireplace with a damaged chimney—it could start a fire or let poisonous gases into your building.
7. *Fallen items.* Beware of items tumbling off shelves when you open the doors of storage units.

---

## Check Your Food and Water Supplies

1. If power is off, plan meals to use up foods that will spoil quickly, or frozen foods. If you keep the door closed, food in your freezer should be good for at least a couple of days.
2. Don't light your kitchen stove if you suspect a gas leak.
3. Use barbecues or camp stoves, outdoors only, for emergency cooking.
4. If your water is off, you can drink supplies from water heaters, melted ice cubes.

Note: The information in these sections is reproduced in whole or in part with the permission of the copyright owner, SBC. The Survival Guide is available in the White Pages of SBC Directories © SBC 2004. This information was provided by medical and emergency service authorities and published as a public service. While every reasonable effort was made to ensure its accuracy, SBC is not responsible and assumes no liability for any action undertaken by any person in utilizing such information. Any person relying upon such information does so at his or her own risk.

### Do Not . . .

- **Do not** eat or drink anything from open containers near shattered glass.
- **Do not** turn the gas on again if you turned it off; let the gas company do it.
- **Do not** use matches, lighters, camp stoves or barbecues, electrical equipment—including telephones—or appliances until you are sure there are no gas leaks. They may create sparks that could ignite leaking gas and cause an explosion and fire.
- **Do not** use your telephone, except for a medical or fire emergency. You could tie up lines needed for emergency response.  
If you need help and the phone doesn't work, send someone for help.
- **Do not** expect firefighters, police, or paramedics to help you right away. They may not be available.

# RESOURCE ORGANIZATIONS

*Some of the organizations listed below have information to help you strengthen your building against earthquakes and help you and your building's occupants prepare a personal earthquake response plan. Other resources that can help you may be available in your community; check your local telephone directory.*

## Building Safety Information

### Office of Emergency Services

#### Main Office

Information and Public Affairs  
P.O. Box 419047  
Rancho Cordova, CA 95741-9047  
Telephone: (916) 845-8400  
<http://www.oes.ca.gov>

#### Regional Offices:

##### Coastal Region

1300 Clay Street, Suite 408  
Oakland, CA 94612  
Telephone: (510) 286-0895

##### Inland Region

P.O. Box 419047  
Rancho Cordova, CA 95741-9047  
Telephone: (916) 845-8470

##### Inland Region South

2550 Mariposa Mall, Room 181  
Fresno, CA 93721  
Telephone: (559) 445-5672

##### Southern Region

4671 Liberty Avenue  
Los Alamitos, CA 90720  
Telephone: (562) 795-2900

### California Seismic Safety Commission

1755 Creekside Oaks Drive, Ste. 100  
Sacramento, CA 95833  
Telephone: (916) 263-5506  
[www.seismic.ca.gov](http://www.seismic.ca.gov)

## Structural Safety Information

### American Institute of Architects

Local chapters have referral lists of licensed architects; consult telephone directory listing for "American Institute of Architects."  
<http://www.aia.org>

### Structural Engineers Association of California

1730 I Street, Suite 240,  
Sacramento, CA 95814-3017  
Telephone: (916) 447-1198  
<http://www.seaoc.org>

Local chapter organizations have referral list for licensed structural engineers as follows:

San Diego - <http://www.seaosd.org>  
Southern California - <http://www.seaosc.org>  
Northern California - <http://www.seaonc.org>  
Central California - <http://www.seaocc.org>

### Consulting Engineers and Land Surveyors of California

1303 J Street, Suite 450  
Sacramento, CA 95814  
Telephone: (916) 441-7991  
<http://www.celsoc.org/>

A referral list for licensed engineers is available.

### International Code Council

5360 Workman Mill Road  
Whittier, CA 90601-2298  
Telephone: (800) 284-4406  
<http://www.iccsafe.org>

## Geologic Information

### Association of Bay Area Governments

P.O. Box 2050  
Oakland, CA 94604  
Telephone: (510) 464-7900  
<http://www.abag.ca.gov>

A consortium of local governments in the San Francisco Bay Area, offering a variety of information, including lists of local resources.

### California Geological Survey

California Department of Conservation  
801 K Street, MS 12-30  
Sacramento, CA 95814  
Telephone: (916) 445-1825  
<http://www.consrv.ca.gov/cgs>

The CGS is the state agency responsible for geological research, mapping, and policy. It provides maps and other information to the general public.

### Southern California Earthquake Center

University of Southern California  
3651 Toursdale Parkway, Suite 169  
Los Angeles, CA 90089-0742  
Telephone: (213) 740-5843  
<http://www.scec.org>

### United States Geological Survey

Earth Science Information Center  
345 Middlefield Road  
Menlo Park, CA 94025  
Telephone: (650) 853-8300  
<http://www.usgs.gov>

This is the federal agency responsible for geological and earthquake hazard research, mapping, and policy. It provides maps and other information to the general public.

### Cities and Counties

Consult your telephone directory under city or county government listings for the office of emergency services or disaster management, city or county building and planning department, and city or county government geologist.

## Emergency Planning Information

### Federal Emergency Management Agency

Region IX  
1111 Broadway, Suite 1200  
Oakland, CA 94607  
Telephone: (510) 627-7100  
<http://www.fema.gov>

FEMA offers a publications lists and referrals to preparedness organizations. FEMA also provides information on Federal Disaster Aid Programs that become available after Federal disasters.

### American Red Cross

Consult your telephone directory for the address and phone number of your local chapter.  
<http://www.redcross.org>



## How to Fill out the Disclosure Form

***When you sell a building that has either:***

- ***precast (tiltup) concrete or reinforced masonry walls with wood-frame floors or roofs, built before 1975 or***
- ***unreinforced masonry , or***
- ***non-ductile concrete, or***
- ***a soft or weak story or open front, or***
- ***a steel frame built before 1995;***

***You are encouraged to fill out the form shown on the next page.***

- Sellers should hand buyers a **completed** disclosure report.
- Sellers should answer the questions to the best of their knowledge.
- If a question on the form describes only part of your building—for example if part of your building is anchored to the foundation and the other part is not—sellers should answer the question with a “NO” because a portion of the building is not properly anchored.
- Sellers are not required to remove siding, drywall, or plaster in order to answer the questions.
- Sellers are not required to hire anyone to inspect their commercial properties.
- Sellers are not required to fix the weaknesses before they sell their commercial properties.

***The Seismic Safety Commission believes that owners have a duty to warn of, & correct seismic hazards:***

***“Private-sector owners and operators of buildings of types that have historically proven hazardous in earthquakes should seek the advice of both a Structural Engineer and legal counsel on satisfying their duty to inform foreseeable victims of any hazard posed by such buildings.”***

(The Right to Know: Disclosure of Seismic Hazards in Buildings, CSSC 92-03, 1992)

# Commercial Property Earthquake Disclosure Report (2006 Edition)

NAME	ASSESSOR'S PARCEL NO.
STREET ADDRESS	YEAR BUILT
CITY AND COUNTY	ZIP CODE

Answer these questions to the best of your knowledge. If you do not have actual knowledge as to whether the weakness exists or not, answer "Don't Know." If you know that a weakness exists or has been corrected or that the building has been seismically retrofitted, explain on a separate sheet. If your property does not have the feature described in the question, answer "Doesn't Apply." The pagenumbers in the right-hand column indicate where in this guide you can find information on each of these features.

	Yes	Doesn't No	Apply	Don't Know	See Page
1. Is the water heater braced, strapped, or anchored to resist falling during an earthquake?	<input type="checkbox"/>	<input type="checkbox"/>	<input type="checkbox"/>	<input type="checkbox"/>	12
2. If the building has precast (tiltup) concrete or reinforced masonry walls with wood-frame floors or roof, are the exterior walls adequately anchored to the floors and the roof in accordance with local building codes?	<input type="checkbox"/>	<input type="checkbox"/>	<input type="checkbox"/>	<input type="checkbox"/>	14
3. If the exterior walls, or part of them, are made of unreinforced masonry, have they been strengthened in accordance with the California Building Standards Code?	<input type="checkbox"/>	<input type="checkbox"/>	<input type="checkbox"/>	<input type="checkbox"/>	16
4. If the building is located in Seismic Zone 4 and has unreinforced masonry bearing walls that have not been retrofitted, has it been posted as potentially unsafe?	<input type="checkbox"/>	<input type="checkbox"/>	<input type="checkbox"/>	<input type="checkbox"/>	17
5. If the building has concrete columns, were they adequately reinforced to resist earthquakes or have they been strengthened?	<input type="checkbox"/>	<input type="checkbox"/>	<input type="checkbox"/>	<input type="checkbox"/>	18
6. If the building has a steel frame built before 1995, has it been inspected for fractures in welds in or near steel connections?	<input type="checkbox"/>	<input type="checkbox"/>	<input type="checkbox"/>	<input type="checkbox"/>	21
7. If your building is commercial or has five or more residential units, does it have a soft or weak story or open front?	<input type="checkbox"/>	<input type="checkbox"/>	<input type="checkbox"/>	<input type="checkbox"/>	22
8. Does the building have well-anchored exterior cladding with no unusual or irregular building features?	<input type="checkbox"/>	<input type="checkbox"/>	<input type="checkbox"/>	<input type="checkbox"/>	25
9. Is the building outside an Alquist-Priolo Earthquake Fault Zone (an area prone to fault rupture immediately surrounding active earthquake faults)?	<input type="checkbox"/>	<input type="checkbox"/>	<input type="checkbox"/>	<input type="checkbox"/>	40
10. Is the building outside a Seismic Hazard Zone (zone identified as susceptible to liquefaction or landsliding)?	<input type="checkbox"/>	<input type="checkbox"/>	<input type="checkbox"/>	<input type="checkbox"/>	41

Keep your copy of this form for future reference

If any of the questions are answered "No," the building may be likely to suffer severe damage during earthquakes. Questions answered "Don't Know" may indicate a need for further evaluations. If you corrected one or more of these weaknesses, describe the work on a separate page.

As seller of the property described herein, I have answered the questions above to the best of my knowledge in an effort to disclose fully any potential earthquake weaknesses it may have. Other earthquake concerns may be present but are not disclosed.

## EXECUTED BY

\_\_\_\_\_  
(Seller)

\_\_\_\_\_  
(Seller)

\_\_\_\_\_  
Date

I acknowledge receipt of this form, completed and signed by the seller. I understand that if the seller has answered "No" to one or more questions, or if seller has indicated a lack of knowledge, there may be one or more earthquake weaknesses in this property.

\_\_\_\_\_  
(Buyer)

\_\_\_\_\_  
(Buyer)

\_\_\_\_\_  
Date



**CLAIM FOR SEISMIC SAFETY CONSTRUCTION  
EXCLUSION FROM ASSESSMENT**  
(Section 74.5 of the Revenue and Taxation Code)

*This form must be filed with the Assessor prior to, or within 30 days of, completion of construction.*

**SAMPLE FORM**  
for Santa Clara County

FOR ASSESSOR'S USE ONLY	
<input type="checkbox"/> Received _____	
<input type="checkbox"/> Approved _____	
<input type="checkbox"/> Denied _____	
Reason for denial _____	
_____	

PROPERTY DESCRIPTION	
Parcel No.(s) _____	
Address _____	
_____	
_____	

**STATEMENTS**

1. As the owner of the property described above, I completed, or will complete, construction on this property on \_\_\_\_\_, and therefore claim the construction exclusion from assessment provided by section 74.5 of the California Revenue and Taxation Code.
2. I understand this exclusion from assessment is applicable only to seismic retrofitting improvements and improvements utilizing earthquake hazard mitigation technologies, to an existing building or structure and is not applicable to alterations, such as new plumbing, electrical, or other added finishing materials, made in addition to seismic-related work performed on an existing structure.
3. I further understand this exclusion from assessment does not encompass the exclusion provided by Revenue and Taxation Code section 70(d) pertaining to the portion of reconstruction or improvement to a structure, constructed of unreinforced masonry bearing wall construction, necessary to comply with any local ordinance relating to seismic safety during the first 15 years following that reconstruction or improvement.
4. The property owner, primary contractor, civil engineer, or architect  has  has not certified to the building department those portions of the project that are seismic retrofitting improvements or improvements utilizing earthquake hazard mitigation technologies.

THIS EXCLUSION EXPIRES UPON CHANGE IN OWNERSHIP OF THE PROPERTY

**CERTIFICATION**

*I certify (or declare) under penalty of perjury under the laws of the State of California that the foregoing and all information hereon, including any accompanying statements or documents, is true, correct, and complete to the best of my knowledge and belief.*

SIGNATURE _____	
	
DATE _____	DAYTIME PHONE NO. _____ (    )

Only the owner or a co-owner of the above-described property (including a purchaser under contract of sale) or his or her legal representative may sign.

If you are buying this property under an unrecorded contract of sale and the Assessor does not have a copy of the contract, you must attach a copy to the claim.

**SUPPORTING DOCUMENTS MUST BE FILED WITHIN SIX MONTHS OF COMPLETION OF THE PROJECT.**